



PRODUCT GUIDE

2020/2021

www.wolff-tools.com

GOING BEYOND YOUR LIMITS



REMOVING FLOORING

Stripping _____	8
Cutting _____	23
Scraping _____	24



PREPARING SUBFLOORS

Grinding _____	26
Milling _____	42
Vacuuming _____	44
Stirring _____	52
Smoothing _____	54



MEASURING INSTRUMENTS

Measuring devices _____	65
Test kit _____	70



USEFUL TOOLS

Knives _____	108
Straight edges _____	110
Work safety equipment _____	114



**18V CORDLESS
TOOL RANGE**

Removing _____ 75
 Stirring _____ 76
 Cutting _____ 77
 Grooving _____ 78
 Sawing _____ 79



APPLYING FLOORS

Linoleum _____ 81
 Vinyl _____ 82
 Rubber _____ 82
 Milling _____ 88
 Welding _____ 92
 Textile floors _____ 96



**CLEANING
AND CARE**

Cleaning _____ 119
 Care _____ 120



WOOD FLOORING

Wood sanding machines _____ 122
 Abrasives _____ 127



SERVICE

Service _____ 134



THE WOLFF 18V RANGE. POWERFUL BATTERY PERFORMANCE.

We introduce the WOLFF 18V range of battery powered tools.
A single battery pack and charger can be used for all devices.

Work more efficiently and with better freedom.

Be less restricted and more effective.



JUNIO-STRIPPER 18V
See page 75



LS 35-65 18V
See page 77



PIRANHA 18V
See page 79



MASTERGROOVER 18V
See page 78



CORDLESS MIXER 18 V
See page 76



Equipment:

#10930	Replacement battery, 18V 5Ah
#10939	230V charger EU
#11772	Charger 230V UK
#11770	Charger 115V USA

Dear WOLFF customers,

Dear craftsmen,

In our WOLFF product guide you will find an extensive range of great machines and first-class tools for preparing and installing floors. Of course, our product portfolio would be nothing without our skilled and experienced employees. Their daily service helps with advice and practical support.

For 2020 we have revolutionised the BiTurbo stripper with Wolff IMM, the intelligent support for your projects. The machine data is made transparent via a chip within the machine. This enables you to plan the best use of the machine and increase your productivity. It can help effectively plan and manage maintenance as well as reduce losses and labour costs. We also present the WOLFF-18V range for safer and more efficient working. The battery can be interchanged between these powerful tools, allowing more freedom and better performance when working.

Our drive is to make your everyday life as simple and efficient as possible. That's what we stand for. We are convinced that you can feel the quality and passion we put into our tools, which we like to share with you. We are only satisfied if you are excited and enjoy working with WOLFF.

We hope you enjoy our product guide. If you don't know exactly which of our tools or machines you need, you've come to the right place. We are happy to help with comprehensive support and advice regarding product selection as we want to ensure you work effectively.

We look forward to our successful cooperation!



Jürgen Rehmann
Managing Director Wolff



Julian Utz
Managing Director Wolff



REMOVING FLOORING



STRIPPING | CUTTING | SCRAPING

ROBO-STRIPPER

The Power of WOLFF



#73888 - 230V (EU)

Robo-Stripper

#74000 - 115V (UK)

- easy blade (UK) replacement (integrated lifting mechanism)
- quick to dismantle for easy transportation
- zero hand vibration
- 2-handed remote control
- extremely maneuverable
- 3-position blade angle adjustment
- torsion joint to provide a stable and level blade
- integrated transport castors with directional lock
- anchor points for secure transport and lifting
- adjustable rate of impact

Technical specifications:

supply voltage: 230 V/115V, 50 Hz, drive power: 2 x 0.9 kW, impact system power: 1.3 kW, impact system strokes: 3000 rpm, width of blade: 350 mm standard – 450 mm optional, weight: approx. 300 kg (can be disassembled), Speed: 0 to 30 m/min, performance: approx. 100-250 m²/h

Includes:

Robo-Stripper, protective gloves, 1 blade 350 x 60 x 1.0 mm, 1 U-blade top cutting edge, 1 U-blade bottom cutting edge, tool set, blade protection, goggles, hearing protection, grease gun

INFO

BLADES FOR ROBO-STRIPPER SEE PAGE 16

ACCESSORIES FOR ROBO-STRIPPER

Twin wheels

Mountable with 3 screws to widen the track for improved traction

#74215



Deflector and oscillator set 450 mm

Deflector and oscillator set 450 mm

#82333



Spare blades

450 x 120 x 1.5 mm

#75006

450 x 60 x 1.5 mm

#75007



Special U-shape blade

450 mm top cutting edge (for hard floors)

#75010

450 mm bottom cutting edge (for soft floors)

#75011



top cut

bottom cut



Special blades for removing floors

for multi-layer and solid wood, with special deflector for the deflection of bigger pieces, **only for ROBO-Stripper and BiTurbo-Stripper.**

350 x 150 x 3.0 mm with deflector (Set)

#80359

spare blade 350 x 150 x 3.0 mm

#79634

350 x 150 x 3.0 mm serrated, with deflector

#80358

spare blade 350x150x3mm serrated

#79635

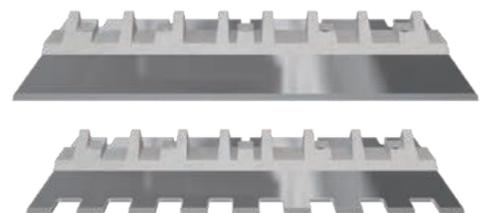

Locking device for torsion joint

Prevents the lateral tilting of the oscillator with narrow blades

#80274



BITURBO-STRIPPER

The benchmark in efficiency and comfort



Simple control
of driving
direction and speed

Torsion compensation

Very quick and easy to
dismantle

Blade angle adjustment

#85000 - 230V (EU)

BiTurbo-Stripper

#88784 - 115V (UK)

- removing all textile and resilient floor coverings
- removing wooden flooring
- high operating comfort due to self-propulsion (forwards and backwards)
- adjustable speed between 0 and 27 m/min
- adjustment to different floorings and working conditions by blade angle adjustment
- torsion compensation for efficient removal
- easy transport, as weights can be removed and the machine can be divided in the middle
- handle height adjustable in 3 steps
- excellent cutting results due to linear blade movement
- easily accessible cockpit controls

Technical specifications:

Supply voltage: 230 V/115 V , 50 Hz, power consumption striking mechanism: 1.5 kW, power consumption drive: 1.5 kW, number of strokes: 3000 strokes/min, blade width: 350 mm, weight: approx. 260 kg (dismountable in 8 pieces), speed 0 to 27 m/min, working capacity: approx. 100 - 150 m²/h

Includes:

BiTurbo stripper, 1 blade 350 x 60 x 1.0 mm, 1 blade 350 x 60 x 1.5 mm, 1 blade 350 x 120 x 1.5 mm , 1 blade 350/200 x 120 x 3.0 mm offset, 1 U-blade top cutting edge, 1 U-blade bottom cutting edge, additional weights, hearing protection, protective gloves, tool set, extension cable, grease gun

INFO

BLADE CASES ON PAGE 15
BLADE SELECTOR ON PAGE 17

INTELLIGENT MACHINE MANAGEMENT BY WOLFF

FROM Q2/2020 IN EVERY BITURBO-STRIPPER

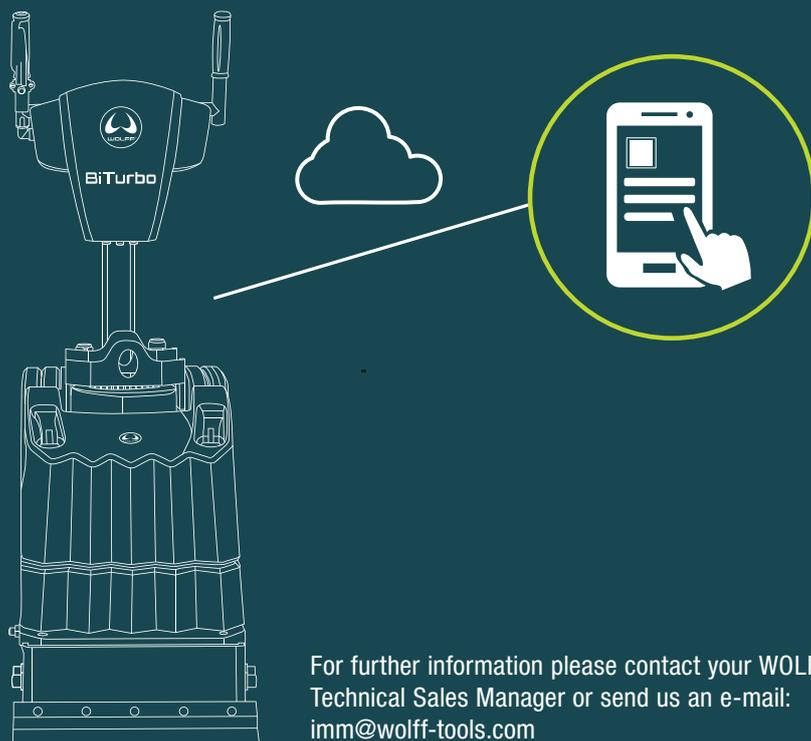

- With Wolff IMM your machine fleet is in your pocket:
- Better transparency: Monitor performance and improve productivity
- IMM helps you identify the location of each machine
- Enhance planning and manage maintenance, reduce machine losses and labour costs
- Reduce downtime on construction sites and reduce repair costs

For further information please contact your WOLFF Technical Sales Manager or send us an e-mail: imm@wolff-tools.com

ACCESSORIES FOR THE BITURBO-STRIPPER

Special blade for wood and floor covering removal

Special blade for wood and floor covering removal with special deflector for better clearance of larger debris. **Only suitable for the ROBO and BiTurbo Stripper!**

350 x 150 x 3.0 mm with screwed-on blade holder (in set)	#80359	Spare blade 350 x 150 x 3.0 mm	#79634
350 x 150 x 3.0 mm serrated with screwed-on blade holder (in set)	#80358	Spare blade serrated 350 x 150 x 3.0 mm	#79635

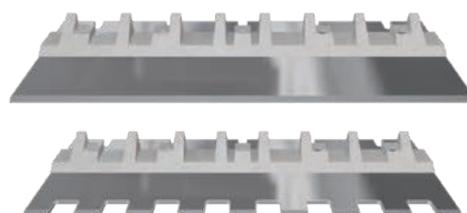

INFO

REPLACEMENT BLADE FOR BITURBO-STRIPPER SEE PAGE 16

Chassis

Suitable for BiTurbo, Turbo and Extro Strippers #62227



TURBO-STRIPPER - THE ORIGINAL

No. 1 worldwide

Control panel operation: All switches are easily accessible for more convenient operation

Angle and height adjustable handle

Weight can be adjusted into 3 positions



#43778 - 230V (EU)

Turbo-Stripper

#39086 - 115V (US)

#39087 - 115V (UK)

- removal of all bonded floor coverings
- new clutch system for smoother operation
- 2.6 kW motor with starting current limiter
- self-propelled with hand-operated clutch for more convenient operation
- emergency stop button for safe operation
- detachable weight and handle for easy transportation
- charging port for USB-devices in the control panel

INFO

BLADES FOR TURBO-STRIPPER SEE PAGE 16

Technical specifications:

230 V/115 V, 2,600 W, starting current limiter, max. working width 150 – 350 mm, 5.000 strokes/min, weight: 157 kg, stripping capacity approx ca. 60 – 100 m²/h

Includes:

Turbo-Stripper, 1 blade 350 x 60 x 1 mm, 1 blade 350 x 60 x 1.5 mm, 1 blade 200 x 60 x 1.5 mm, 1 blade 150 x 60 x 1.5 mm, 1 U-shape blade with top cutting edge, 1 U-shape blade with bottom cutting edge, tool kit, hearing protection, safety gloves, blade cover, extension cable

Accessories:

Three-star grip screw M 10 x 80 for fixating the additional weight

#39234

Three-star grip nut D 80 x M 10 for fixating the hood

#39189

ACCESSORIES FOR TURBO-STRIPPER

Additional weight, 30 kg

for Turbo-Stripper

#38535



Undercarriage

suitable for BiTurbo, Turbo and Extro

#62227



Special blade

Heavy duty, angled, for heavy floorings, 350 mm.

For new stripper versions

#39362

For old stripper versions

#15532



Wood flooring stripper set

The perfect set for stripping wood flooring. An add-on to the Turbo Stripper

#63754

Includes:

Deflector for new Turbo version

#63752

Undercarriage protection

#53415

Blade for multi layer wood flooring

#13982

Blade holder for wood flooring stripper set

#73389

Special blade (heavy duty)

#39362

Blade holder for deflector for new Turbo versions

#63753



Drive belt Turbo

for Turbo and Extro Stripper

#14938

Impact belt Turbo

for Turbo and Extro Stripper

#14937

EXTRO-STRIPPER

Stripper with Pull-Back-System

Control panel:
All switches are easily
accessible for more
convenient operation



Height-adjustable handle



With Pull-Back-System



#38588 - 230V (EU)

Extro-Stripper

#39121 - 115V (UK)

#39090 - 115V (US)

- perfect combination of impact power and self-propulsion for maximum efficiency
- charging port for USB-devices in the control panel

Technical specifications:

230 V/115 V, 2,600 W, 5,000 strokes/min, weight 112 kg, weight of detachable hood 42 kg, blade width 350 mm, stripping capacity approx. 80 m²/h

Includes:

Extro-Stripper, 1 blade 350 x 60 x 1 mm, 1 blade 350 x 60 x 1.5 mm, 1 blade 200 x 60 x 1.5 mm, 1 blade 150 x 60 x 1.5 mm, 1 U-shape blade with top cutting edge, 1 U-shape blade with bottom cutting edge, tool kit, hearing protection, safety gloves, blade cover, extension cable

ACCESSORIES FOR EXTRO-STRIPPER

Three-star nut D 80 x M 10

for fixating the hood

#39189

Chassis

Suitable for BiTurbo, Turbo and Extro Strippers

#62227

INFO

BLADES FOR EXTRO-STRIPPER SEE PAGE 16

BLADE CASE FOR TURBO AND BITURBO



BLADE CASE FOR VARIO STRIPPER



#88634

Blade case for Turbo and BiTurbo Strippers

Blade case for the Turbo and BiTurbo Stripper with a selection of blades for different applications. The case contains two space saving insert compartments, so that the blades are safe when transported. In addition there is enough space to accommodate other tools.

Technical data:

Weight: 10.5 kg

Scope of delivery:

1 x transport case, 2 x compartments for blades, 10 x spare blades 350 x 60 x 1.5 mm, 2 x spare blades 350 x 120 x 1.5 mm, 5 x U-shape blades 350 top cutting edge, 1 x U-shape blade 350 bottom cutting edge, 1 x wood blade 200 x 120 x 3 mm, 1 x blade 350 x 60 x 1.5 mm serrated, 10 x spare blades 350 x 60 x 1.0 mm

#88635

Blade case for Vario Stripper

Blade case for the Vario Stripper with all important blades for the different applications. The case contains two space saving insert compartments, so that the blades are safe when transported. In addition there is enough space to accommodate other tools.

Technical data:

Weight: 8.0 kg

Scope of delivery:

1 x transport case, 2 x compartments for blades, 10 x spare blades 250 x 60 x 1.0 mm, 10 x replacement blades 250 x 60 x 0.7mm, 10 x replacement blades 250 x 60 x 1.5 mm, 5 x U-shape blades 250 top cutting edge, 1 x U-shape blade 250 bottom cutting edge, 1 x serrated blade 250 x 60 x 1 mm

SPARE BLADES AND SPECIAL BLADES FOR ROBO, BITURBO AND EXTRO-STRIPPERS

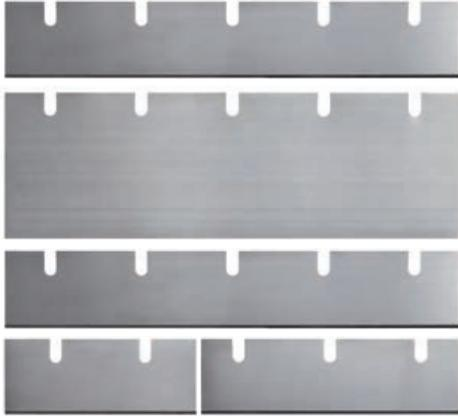

Spare Blades

for textile

350 x 60 x 1.0 mm 10 pcs.

#13978

for multi-layer wood flooring

350 x 120 x 1.5 mm 1 pcs.

#13982

For linoleum, PVC and rubber floorings

350 x 120 x 1.5 mm 1 pcs.

#13982

350 x 60 x 1.5 mm 10 pcs.

#13979

150 x 60 x 1.5 mm 10 pcs.

#13981

200 x 60 x 1.5 mm 10 pcs.

#13980



Special 350 mm U-shape blade

To simultaneously cut and remove flooring. Angled on one side.

Top cutting edge

#13983

Angled

#38933



top cut

bottom cut



Special blade

350 x 120 x 3.0 mm

#79636



Special blade

350/200 x 120 x 3.0 mm

#79637



Special blade

for strongly bonded flooring

350/100 x 120 x 3.0 mm

#79638



Special blade

for multi-layer parquet

350 x 120 x 3.0 mm

#79639



Special blade

for flooring with fleece backing

350 x 60 x 1.5 mm

#81205

BLADE SELECTOR FOR ROBO, BITURBO, TURBO AND EXTRO-STRIPPERS

Blades

350 x 60 x 1.0 350 x 60 x 1.5 350 x 120 x 1.5 350 x 120 x 3.0 350/200 x 120 x 3.0 350/100 x 120 x 3.0 350 x 120 x 3.0 350 x 60 x 1.5

#13978	#13979	#13982	#79636	#79637	#79638	#79639	#81205
	also available with U-shaped blades				serrated	serrated	serrated edge

Floor covering

Textile flooring with SDB and woven goods	●						
Textile flooring with fleece or foam backing							●
CV covering in sheets	●	●	●				●
Vinyl flooring in sheets and tiles		●					
Rubber flooring in sheets		●					
Linoleum up to 2.5 mm in sheets and tiles		●					
Linoleum with more than 2.5 mm				●	●		
Linoleum with more than 3.5 mm				●	●		
Solid wood flooring (10 - 22 mm)					●	●	
Multi-layer wood with stabilizing layer			●		●	●	●
Two layer wood with MDF or HDF						●	●
End grain wood block flooring					●	●	
Glued and nailed chipboards						●	
Sport-composite flooring		●		●	●		
Needle punch carpet		●					
Ceramic tile (small)						●	

Some of the blades with 1.5 mm thickness are also available in narrow sizes, especially for parts with strong bonding. This selector does not replace a detailed review of the circumstances on the construction site. Wolff does not claim any responsibilities for damages at the building or the tools that are based on incorrect use.

VARIO-STRIPPER SILENT

Extremely quiet stripper for use on medium-sized areas

Vario drive:

Variable speed control
up to 17 m/min

Extremely quiet motor

With Pull-Back-System

Height adjustable handle



#38764 - 230V (EU)

Vario-Stripper Silent

#42453 - 115V (UK)

#50202 - 115V (US)

- removes PVC, linoleum and rubber floor coverings
- silent motor makes it possible to use the machine even during normal working hours (hospitals, office buildings)
- self-propelled machine and controls integrated into the top of the handle for great, convenient operation
- easy transportation thanks to detachable weight and handle
- Pull-Back-System for safe operation in corners and along walls
- Vario drive: variable speed control between 2.5 and 17 m/min
- interchangeable blade adapters can be used to adjust to different floorings and working conditions
- charging port for USB-devices in the control panel

Technical specifications:

230 V/115 V, 1,650 W, 3,000 strokes/min, basic weight 107 kg (weight of basic machine 60 kg, additional weight of detachable hood 30 kg, removable handle 17 kg, max. working width 250 mm, limiting speed 2.5 – 16 m/min, stripping capacity ca. 30 – 70 m²/h, with soft start

Includes:

Vario-Stripper Silent, 1 blade 250 x 60 x 0.7 mm, 1 blade 250 x 60 x 1 mm, 1 blade 250 x 60 x 1.5 mm, 1 U-shape blade with top cutting edge, 1 U-shape blade with bottom cutting edge, tool kit, safety gloves, blade cover, extension cable

INFO

BLADE CASE FOR VARIO SEE PAGE 15

ACCESSORIES FOR VARIO-STRIPPER

Blade case for Vario Stripper

Blade case for the Vario Stripper with all important blades for different applications. The case contains two space saving insert compartments, so that the blades are safe when transported. In addition there is enough space to accommodate other tools.

Blade case for Vario Stripper

#88635



Spare blades

For textile flooring.

250 x 60 x 0.7 mm 10 pcs.

#38765

For linoleum, PVC and rubber floorings.

250 x 60 x 1.5 mm 10 pcs.

#38767

250 x 60 x 1.0 mm 10 pcs.

#38766



Serrated blades

To remove floors with felt or fleece backing.

The serrated blade cuts the fibres perfectly. The blades are made of high-quality hardened and specially coated spring band steel with CNC controlled sharpening.

250 x 60 x 1.0 mm

#48401



Special U-shape blade, 250 mm

To cut and remove floor coverings simultaneously (for PVC and linoleum). Angled on one side.

Top cutting edge

#38768

Bottom cutting edge

#38932

top cut

bottom cut



PULL-BACK-SYSTEM

The Pull-Back System has been developed to make it easy to reverse the Extro-Stripper and Vario-Stripper Silent.

When you reach a wall or another obstacle while you are working, simply pull back the handle to raise the driving wheels. The machine stops although the wheels continue to rotate.

Pull the handle harder to pull the machine back to where you want to start the next line.

Push the handle forward to lower the driving wheels back to the ground and the machine will start to move forward again.

When working, push the handle forward slightly to raise the small transport wheels.

DURO-STRIPPER 2.0

Best seller – Number 1 worldwide for universal use on small to medium-sized areas



#84888 - 230V (EU)

Duro-Stripper 2.0

#85641 - 115V (UK)

#85641 - 115V (US)

- can be operated as a handheld machine with the removal of the handle.
- rugged metal casing for heavy-duty use
- special bearings to reduce vibrations
- complete with wheels for easier operation

Technical specifications:

230 V/115 V, 2,000 W, starting current limiter, working width 210 mm, 8,500 rpm, weight: 16 kg

Includes:

Duro-Stripper, 1 blade 210 x 50 x 0.7 mm, 1 blade 210 x 60 x 1 mm, tool kit, hearing protection, safety gloves, blade cover

Duro-Stripper VG (with adjustable grips)

Model with adjustable grips - 230V (EU)

#85652



ACCESSORIES FOR DURO-STRIPPER

Spare blades

For textile flooring.			for linoleum, vinyl, rubber.		
210 x 60 x 0.7 mm	10 pcs.	#13344	210 x 60 x 1.0 mm	10 pcs.	#13345
			210 x 60 x 1.5 mm	10 pcs.	#13346



Serrated blades

To remove floors with felt or fleece backing.

The serrated blade cuts the fibres perfectly. The blades are made of high-quality hardened and specially coated spring band steel with CNC controlled sharpening.

210 x 60 x 1.0 mm	#48402
-------------------	--------



Metal carrying case

Metal carrying case	#13349
---------------------	--------



Spare wheels

(only for Duro-Stripper)	#85357
--------------------------	--------



PRIMO-STRIPPER

Cost effective machine for universal use on small to medium-sized areas



- Light and maneuverable
- 2.0 kW consumption
- Ideal for working close to walls

JUNIO-STRIPPER

For removing small areas of textile floor coverings, foam or flooring residues and glass fibre wall coverings

**BATTERY OPERATED
DEVICE 18V AVAILABLE.**

See page 75



- Robust device
- 1,010 W consumption
- Light and handy



Spare blade 200 mm

#82348 - 230V (EU)

Primo-Stripper

- can be operated as a handheld machine with the removal of the handle.
- 2.0 kW motor with starting current limiter

Technical specifications:

230V, 2,000W, 6,600 rpm, working width 210 mm, weight 13.5 kg

Includes:

Primo-Stripper, 1 blade 210 x 60 x 1 mm, tool kit, hearing protection, safety gloves, blade cover

Spare blades:

210 x 60 x 0.7 mm (for Textile), 10 pcs.	#13344
210 x 60 x 1.0 mm (for Vinyl), 10 pcs.	#13345
210 x 60 x 1.5 mm (for Linoleum, Vinyl, Rubber), 10 pcs.	#13346

Serrated blade for Primo-Stripper

To remove floorings with felt or fleece backing. The serrated blade cuts the fibres perfectly. The blades are made of high-quality hardened and specially coated spring band steel with CNC controlled sharpening.

Serrated blade 210 x 60 x 1.0 mm	#48402
----------------------------------	--------

PRIMO-STRIPPER VG

Design with adjustable grips

#82349

#16876 - 230V (EU)

Junio-Stripper

#20819 - 115V (UK)

#50080 - 115V (US)

- allows you to work in difficult places like window recesses and under radiators
- perfect for areas near stairs or along walls
- includes carrying case

Technical specifications:

230 V/115 V, 1,010 W, max. working width 120/200 mm, weight: 3.1 kg

Includes:

Junio-Stripper, 1 blade 120 mm, tool kit, safety gloves, hearing protection, transport case, blade cover

Accessories:

Spare blade 120 mm, 10 pcs.	#13998
Spare blade 200 mm, 10 pcs.	#14000
Leather blade cover	#33199
Combi blade	#15519

WOOD AND SCREED CUTTER PS 230

For fast, precise cutting of wood and screeds



#84919 - 230V (EU)

Wood and screed cutter PS 230

- powerful engine allows continuous use
- adjustable cutting depth from 0 - 60 mm
- access for dust extraction

Technical specifications:

230 V, 2,600 W, 6,500 rpm, Saw-blade diameter 230 mm, cutting depth 0 – 60 mm, diameter of the access for dust extraction 50 mm, weight: 28 kg

Includes:

HM-Blade Ø 230 mm, tools for the saw-blade-change, cable support

Accessories:

Distance piece for wood cutting	#85141
HM-blade 230 mm (standard)	#85147
PCD blade 230 mm (for wood)	#85148
DIA blade 230 mm blue (for hard floors - concrete)	#85541
DIA blade 230 mm (for soft floors - screed)	#85149

ACCESSORIES FOR REMOVING FLOORING

Ergo Cutter Pro

Ideal tool for precutting floors in preparation for stripping.

The long metal handle allows you to work while standing.

Ergo Cutter Pro	#88300	Spare blades for Ergo Cutter Pro (100 pcs.)	#13421
-----------------	--------	---	--------



Carpet clamp

A great aid when removing bonded floorings. Extremely strong and high-quality aluminium.

The ergonomic design protects hands and fingers. Tested to a pulling force of 200 kp.

Carpet clamp	#13342
--------------	--------



Two-handed ripper claw

Made of steel, with spring-mounted clamping jaw and rotating handle.

Width of the handle is suitable for two-handed pulling.

Carpet clamp with wooden handle	#10068
---------------------------------	--------



Floor scraper

Very sturdy design, 300 mm wide, handle length 135 cm.

Floor scraper	#13934
---------------	--------

Spare blade	#14001
-------------	--------

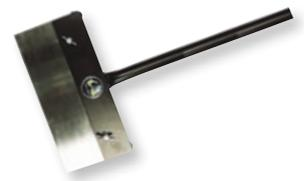

Hand scraper WOLFF

Working width 10 cm, incl. 5 blades.

Hand scraper WOLFF	#51505
--------------------	--------

Spare blades, 100 pcs. in box	#13617
-------------------------------	--------

Spare blades 10 pcs. in dispenser (perforated packaging for hanging)	#89520
--	--------

Replacement screws	#88367
--------------------	--------



Professional hand scraper WOLFF

Working width 52 mm. Supplied without blades.

Professional hand scraper WOLFF	#65500
---------------------------------	--------

Straight blades (100 pcs.)	#13419
----------------------------	--------



PREPARING SUBFLOORS



GRINDING | MILLING | VACUUMING

MAMBO EVO

Grinding machine for all grinding and milling operations



#61804 - 230V (EU)

#62551 - 115V (UK)

#68952 - 115V (US)

Monodisc grinding machine Mambo Evo

- variable speed control from 100 to 400 rpm to match the abrasives perfectly to the surface
- internal dust ring
- finishing grind on wooden floors
- high torque for effective and fast operation, with high abrasion and great power even at low speeds
- additional weight for increased abrasion
- folding handle and detachable weight for easy transportation (dimensions when folded 55 x 40 x 88 cm)
- shock-absorbing disc holder
- height adjustable wheels

Technical specifications:

230 V/115 V, 2,000 W, adjustable speed 100 – 400 rpm, working width 375 – 400 mm, weight 52 kg + 18 kg additional weight, with starting current limiter

Includes:

Mambo grinding machine, protection and dust ring, additional weight, extension cable, comes without disc and suction kit

Accessories:

Cleaning tank	#39709
Extension cable WOLFF (EU plug, shown on p. 28)	#41811
Large dust ring	#20747
Large spare brush	#20993

SAMBA

Single disc grinding machine for all grinding, cleaning and polishing work

- Handy machine with 1,700 W
- Also suitable for wet cleaning
- Ideal for small to medium-sized areas
- Metal wheels as standard



#56364 - 230V (EU)

#65218 - 115V (UK)

#63047 - 115V (US)

Monodisc grinding machine Samba 1,700 W

Versatile and very powerful machine for grinding screeds or compounds. Also suitable for wet cleaning carpet or for polishing hard floors.

- thanks to the powerful motor and the attachable suction kit, subfloors can now be prepared without any problem
- large range of discs and cleaning accessories provide the perfect solution for any task
- reinforced handle
- robust steel gearbox
- metal rims

Technical specifications:

230 V/115 V, 1,700 W, 154 rpm, weight: 44 kg, working width 375/400 mm, robust steel gearbox

Includes:

Grinding machine Samba, without suction and disc holder

Accessories: see page 28

ACCESSORIES FOR SAMBA, FLAMENCO, JIVE AND TANGO:

Additional weight

Increases abrasion

11 kg

#34097



Suction kit plastic

Suction kit complete

#13503 -
230V (EU)

consisting of:

Vacuum with holding basket

#35082

Hose set with T-piece

#14038

Dust ring

#14039

Brush ring

#15353



Suction kit metal

Suction kit complete

#74177 -
230V (EU)

consisting of:

Vacuum with holding basket

#35082

Dust ring with extraction device

#72462

Hose kit for dust ring

#73385



Paper filter bags 40 cm

40 cm, 10 pcs. (for machines built before 2004)

#13504



Paper filter bags 80 cm

80 cm, 5 pcs. (for machines built from 2004 onwards)

#37299



Extension cable WOLFF

25 m 3G x 2.5² Schuko (EU plug)

#41811



Cleaning tank

For wet cleaning with pads and brushes. The cleaning tank is attached to the guide rod of the grinding machine. Tank volume approx. 12 l.

Cleaning tank

#59831



Wheels with metal rims

For retrofitting older models that are equipped with plastic rims.

Wheels with metal rims

#83950



FLAMENCO

- Powerful machine with 2,200 W
- Also suitable for wet cleaning
- Ideal for small to medium-sized areas



#56365 - 230V (EU)

Monodisc grinding machine Flamenco 2,200 W / 154 rpm

Versatile and very powerful machine for grinding screeds or compounds.

- thanks to the powerful motor and the attachable suction kit, subfloors can now be prepared without any problem
- low operating weight
- large range of discs and cleaning accessories provide the perfect solution for any task
- specially reinforced handle
- durable steel gearbox

Technical specifications:

230 V, 2,200 W, 154 rpm, weight: 44 kg, working width 375/400 mm

Includes:

Grinding machine Flamenco, without suction kit and disc holder

Accessories: shown on page 28

JIVE

- Powerful machine up to 1,000 W
- Ideal for small areas
- Also suitable for wet cleaning



#56363 - 230V (EU)

Monodisc grinding machine Jive 2,200 W / 230 rpm

For wet cleaning carpets and polishing of hard floors.

Technical specifications:

230 V, 2,200 W, 230 rpm, weight: 44 kg, working width 375/400 mm

Includes:

Grinding machine Jive, without suction kit and disc holder

Accessories: shown on page 28

TANGO

- Light machine with 1,000 W
- Ideal for small areas
- Also suitable for wet cleaning



#56366 - 230V (EU)

Monodisc grinding machine Tango 1,000 W

Versatile 1.0 kW machine with a broad range of applications.

- grinding screeds and brushing screed or compounds
- sanding wood flooring and cork
- wet cleaning and polishing hard floors
- polishing of oiled and waxed floors

Technical specifications:

230 V, 1,000 W, 154 rpm, weight: 41 kg, working width 375/400 mm

Includes:

Grinding machine, without suction kit and disc holder

Accessories: shown on page 28

GRINDING PLATES FOR MONODISC GRINDING MACHINES SUITABLE FOR THE MAMBO, SAMBA, TANGO, FLAMENCO, AND JIVE

Disc holder with sponge padding

For abrasive paper, HM grinding disc and abrasive gauze.

Diameter 375 mm	#13299	Diameter 400 mm	#13327
Spare sponge padding:			
Diameter 375 mm	#13500	Diameter 400 mm	#13328



Disc holder with felt

Diameter 375 mm

For abrasive paper	#13501	Felt padding	#13526
--------------------	--------	--------------	--------

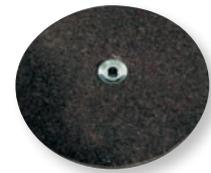

Disc holder accessories

Bolt with left-handed thread	#14044	Spring washer	#14043
Allen key SW 8	#14959		

Abrasive gauze, 10 pcs.

Diameter	150 mm	406 mm
Grit 60	#33511	#12665
Grit 80	#33513	#12666
Grit 100	#33514	#12667
Grit 120	#33515	#12668
Grit 150	#33516	#12669
Grit 180	#33517	#13549



Abrasive paper discs, double-sided, 10 pcs.

Diameter	380 mm	400 mm
Perforation	40 mm	25 mm
Grit 16	#50820	#51243
Grit 24	#13527	#13329
Grit 40	#13528	#13330
Grit 60	#13529	#13534
Grit 80	#13530	#13535
Grit 100	#13532	#13536
Grit 120	#13533	#13537



HM grinding disc, double-sided

For grinding screed or compounds and for removing paint or floor residues. High grinding capacity.

Diameter	375 mm	400 mm
Grit 12	#33291	#33292
Grit 14	#50849	#50850
Grit 16	#13510	#13515
Grit 24	#13517	#13518
Grit 36	—	#38197



GRINDING PLATES FOR MONODISC GRINDING MACHINES SUITABLE FOR THE MAMBO, SAMBA, TANGO, FLAMENCO, AND JIVE

Grinding plate with hard metal ring

The hard metal ring has the same function as the hard metal discs. However, the ring has a longer service life and offers more aggressive grinding. Well suited to removing old fleece residues.

Grit 16	#14254	Grit 24	#14255
---------	--------	---------	--------

Accessories:

Hard metal ring, grit 16	#14256	Hard metal ring, grit 24	#14257
--------------------------	--------	--------------------------	--------

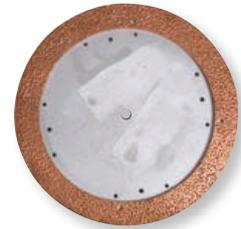

Flat steel brush disc

For scraping foam, felt or jute residues.

For roughening self-spreading anhydrite screed and for industrial floor cleaning.

Wire length 45 mm

Flat steel brush disc	#15738
-----------------------	--------

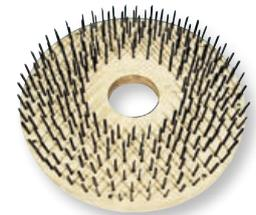

Brush cup plate

For removing the sintered layer of new anhydrite and magnesite screed

#15735

Accessories:

Brush cup set, 6 pcs.	#15736
-----------------------	--------

Mounting kit for brush cup set	#15737
--------------------------------	--------



Multi grinding plate

For final polishing of wood floors and intermediate grinding of floor sealings.

For 4 grinding discs, 150 mm. Incl. extra high brush ring (#40982),

for use with grinding machine Mambo

Multi grinding plate	#14023
----------------------	--------

Accessories:

Brush ring	#40982
------------	--------



Holding kit for perforated pads

Diameter 410 mm

For grinding freshly installed wooden floors, intermediate grinding of varnish, renovating oiled surfaces and treating sealed wood floors (to remove dirt & dust). Also for matting varnished surfaces and treating engineered stone floors.

Holding kit, complete 410 mm	#40607
------------------------------	--------

Dust absorbing pad 410 mm	#42796
---------------------------	--------

Velcro pad	#41043
------------	--------



DISC HOLDERS, BRUSH ATTACHMENTS AND CLEANING PADS

Perforated pads, 10 pcs.

Diameter	150 mm	410 mm
Grit 36	–	#40720
Grit 40	#40775	#40741
Grit 60	#40776	#40742
Grit 80	#40777	#40743
Grit 100	#70754	#40744
Grit 120	–	#40745
Grit 150	–	#40746
Grit 220	–	#40747
Grit 320	#40778	#40748
Grit 400	–	#40749



Disc holder for pads

Diameter 400 mm		
Disc holder for pads	#13300	Spare pad #15739



Cleaning pads

Diameter		150 mm	410 mm	410 mm
Material thickness		10 mm	10 mm	20 mm
Quantity		10 pcs.	10 pcs.	5 pcs.
For high gloss polishing:	white	#33510	#12679	#12693
For waxing and polishing:	beige	#33509	#12676	#12680
For PU coated vinyl	grey	–	–	#80718
For grinding:	red	#33507	#34300	#34298
For basic/maintenance cleaning:	green	#33506	#12677	#12691
For abrasive cleaning of resilient floorings:	brown	–	–	#65080
For abrasive cleaning of ceramic floorings:	black	#33505	#12678	#12692
For oiling:		#33525	#33524	–



150 mm pads for multi grinding plate (shown on p. 31)

Shampooing brush, not illustrated

With soft bristles to clean carpets	#13506
-------------------------------------	--------

Perlon brush, hard

With hard Perlon bristles for rough cleaning of hard flooring (linoleum, PVC, stone, ceramics)	#13507
--	--------



Corrugated wire brush

For brushing and precleaning surfaces	#13539
---------------------------------------	--------

Polishing brush, coir, not illustrated

For brushing and polishing hard flooring (linoleum, PVC, stone, ceramics)	#13505
---	--------



Disc for natural stone

For cleaning natural stone floors. **Not to be used on the monodisc grinding machine Mambo!**

Plate for natural stone	#33209
-------------------------	--------



Scrub brush, not illustrated

For maintenance cleaning of hard flooring with coarse or caked soiling	#13508
--	--------

GRINDING PLATES FOR MONO DISC GRINDING MACHINES FROM 1.7 KW

Grinding disc with 6 stones, grit 20

For grinding screed or compounds and for removing unevenness, paint or plaster residues.

Not suitable for grinding machines < 1.7 kW

Sanding disc with 6 stones grit 20	#13540
------------------------------------	--------

Accessories:

Stone, grit 20	#13490
----------------	--------

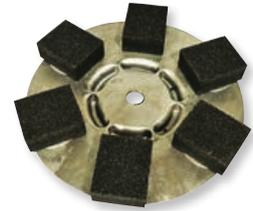

Milling disc with rotation principle

For preparing substrates of any kind. **Not suitable for grinding machines < 1.7 kW**

Milling disc with rotation principle	#34284
--------------------------------------	--------

Accessories:

Single milling module	#34285
-----------------------	--------

Gliding disc	#34286
--------------	--------

Wheel set per module, 12 pcs.	#34288
-------------------------------	--------



Hard metal (HM) milling plate disc

HM milling plates for removing thick layers of adhesive with fibre, felt or foam residues.

Not suitable for grinding machines < 1.7 kW

Hard metal (HM) milling plate disc	#13569
------------------------------------	--------

Accessories:

Milling module with HM plate	#13550
------------------------------	--------

HM Plate (1pc.)	#13566
-----------------	--------



Grinding disc with diamond grinding heads

For grinding all common coatings, compounds and, in particular, concrete floors.

Even extremely hard compounds can be grinded without any problem. **Not suitable for grinding machines < 1.7 kW**

Grinding disc with diamond grinding heads	#14248
---	--------

Accessories:

Diamond grinding head, fan-type helical design	#14249
--	--------



Basic grinding disc for diamond segments

400 mm diameter complete with segment holders for diamond segments.

	#51840
--	--------



DIAMOND GRINDING DISC NINJA

Effective, simple and proven

- Extremely effective diamond grinding plate for all kind of subfloors
- Segments are easy to change due to slide-in system
- Safe and easy application thanks to the diamond segment selector



Diamond grinding disc Ninja

- extremely effective grinding disc for monodisc grinding machines
- high quality and long lasting segments
- easy change of the segments due to a slide-in system
- diamond segments for several applications
- unique WOLFF design

Versions

Ninja complete with PCD Split segments	#68867
Ninja complete with PCD Scraper segments	#68866
Ninja complete with ES K20 segments	#68869
Ninja complete with BT K20 segments	#68868
Ninja Disc without segments	#68392

SEGMENT-SELECTOR – DIAMOND SEGMENTS ARE SUITABLE FOR MONODISC GRINDING MACHINES 150-500 RPM.



Product

BT K20

ES K20

PCD Split

PCD Scraper

#68390

#68391

#68389

#68388

Please choose the right segments for your surface*

Allround segment for medium to hard and hard floors

Allround segment for soft to very soft floors

Removes adhesives and thin layers of levelling compounds and coatings

Aggressive segment with 3 PCD teeth for removal of thick adhesives, tile adhesives, jute and fleece backing, thicker layers of levelling compounds

Hard concrete or similar



Cement screed



Anhydrite screed



Mastic asphalt



Magnesia screed



Epoxy layer, thin



PU coatings



Synthetic resin floorings



Adhesive layers, thin, < 1 mm



Adhesive layers, thick, > 1 mm



Dispersion tackifier



Tile adhesives



Insulated cardboard



Foam and fleece backing



Jute and synthetic secondary backing



* Please read the instructions within the operating manual upon receipt of the goods.

HANDHELD GRINDING MACHINE BS 125

- Excellent grinding capabilities
- Anti-vibration handle



FLOOR GRINDING MACHINE BS 180

- Works up to the edge
- 180 mm working width
- Versatile machine



#80582 - 230V (EU) Handheld grinder BS 125

The compact floor grinding machine from WOLFF.

- excellent grinding capabilities
- soft start electronic and self-cut out carbon brushes
- adjustable cover for detailed edge work and dust-free working
- dust-proof rubber housing
- anti-vibration handle
- spindle lock for easy disc replacement

Technical specifications:

230 V, 50 Hz, 1.5 kW, rotational speed: 11,000 rpm, discs Ø: 125 mm, weight: 2.6 kg

Includes:

Grinding wheel Ø 125 ES K20 black, carrying case, hearing protectors, safety goggles

Accessories:

Spare brush set

#80753

#15930 - 230V (EU) Floor grinding machine BS 180

Hand-operated grinder for preparing subfloors. Can work directly along walls. Versatile machine to grind stairs, platforms or rail systems near edges, and along walls.

- comes with suction hood to work directly along walls
- removes unevenness as well as adhesive and paint residues
- comes with suction outlet and spring-loaded suction hood
- ensures high suction capacity
- includes a grinding disc ES K20

Technical specifications:

230 V, 2,200 W, 6,600 rpm, working width 180 mm, weight 9.5 kg

Includes:

Floor grinding machine BS 180, tool kit, hearing protection, safety goggles, carrying case, 1 grinding disc ES K20 #75407

Accessories:

Brush BS 180

#82650

Grinding disc ES K20

#75407

DISC-SELECTOR



Product

BT K20 gold

#72984 125 mm
#75406 180 mm

ES K 20 black

#72983 125 mm
#75407 180 mm

PCD Split, silver

#75404 125 mm
#75408 180 mm

PCD Scraper, silver

#75405 125 mm
#75409 180 mm

Please choose the right segments for your surface*

Allround segment for medium to hard and hard floors

Allround segment for soft to very soft floor

Flakes of PCD remove adhesives and thin layers of levelling compounds and coatings

Aggressive segment with half-round PCD teeth, for aggressive removal of thick adhesives, tile adhesives, jute and fleece backing, thicker layers of levelling compounds

Hard concrete or similar



Cement screed



Anhydrite screed



Mastic asphalt



Magnesia screed



Epoxy layer, thin



PU coatings



Synthetic resin floorings



Adhesive layers, thin, < 1 mm



Adhesive layers, thick, > 1 mm



Dispersion tackifier



Dispersion tackifier



Insulated cardboard



Foam and fleece backing



Jute and synthetic secondary backing



* Please read the instructions within the operating manual upon receipt of the goods.

ACCESSORIES FOR BS 125 AND BS 180

Grinding disc ES grit 20, black

For soft to very soft subfloors.

ø 125 mm	#72983
ø 180 mm	#75407



Grinding disc BT grit 20, gold

Allround segment for medium to hard and hard subfloors.

ø 125 mm	#72984
ø 180 mm	#75406



Grinding disc PCD Split, silver

For removal of adhesives as well as thin layers of levelling compounds and coatings.

ø 125 mm	#75404
ø 180 mm	#75408



Grinding disc PCD Scraper, silver

For aggressive removal of thick adhesives, tile adhesives, jute and fleece backing, thicker layers of levelling compounds.

ø 125 mm	#75405
ø 180 mm	#75409



ACCESSORIES FOR FLOOR GRINDING MACHINE BS 180

Diamond grinding disc

For repairing concrete and removing coatings.

Diamond grinding disc, single row	#15932	Diamond grinding disc, double row	#15933
-----------------------------------	--------	-----------------------------------	--------



Diamond grinding disc Raptor

Extremely aggressive diamond grinding disc to remove very tenacious old flooring residues such as epoxy and other coatings. **Suitable for removal only!**

Diamond grinding disc Raptor	#15953
------------------------------	--------



HM grinding disc

To remove adhesives and levelling compounds.

HM grinding disc, 180 mm, grit 16	#15934	HM grinding disc, 180 mm, grit 24	#15935
-----------------------------------	--------	-----------------------------------	--------



FLOOR GRINDING MACHINE NEO 230

Our bestseller for subfloor preparation



#74650 - 230V (EU) **Floor grinding machine Neo 230**

#74895 - 115V (UK)

#75382 - 115V (US)

Floor grinding machine for small and medium surfaces.

- ideal for surfaces from 30 to max. 50 m² and for working close to edges and walls
- integrated skirt for dust-free operation
- three adjustable motor positions for working closer to the edge
- floating skirt follows the contours of the floor
- guard with pivoting segments for working close up to walls
- height adjustable and folding handle
- diamond segments are easy to replace

Technical specifications:

Supply voltage: 230 V/115 V, 50 Hz, motor output: 2.0 kW, speed: 1500 rpm, working width: 230 mm, weight: 44 kg, suction connection: 50 mm

Includes:

Neo 230, disc holder for 4 diamond segments, hearing protection, extension cable, without grinding segments, cable cantilever and abrasive tools

Accessories:

Spare brush set

#87313

FLOOR GRINDING MACHINE NEO 400

The beast for large areas



Efficient dust-extraction

aggressive removal

#76970 - 400V (EU) Floor grinding machine Neo 400

Grinding machine for medium to large areas.

- for huge surfaces
- efficient and aggressive removal
- height adjustable
- suction ring with brush
- connecting piece Ø 50 mm
- stabiliser wheel allows easy movement of the machine on soft surfaces
- with a new additional inner brush ring and two suction nozzles

Technical specifications:

Supply voltage: 400 V, 50 Hz, Motor output: 4.0 kW, Speed 1500 rpm, working width: 400 mm, total weight: 95 kg, suction connection: 50 mm

Includes:

Floor grinding machine Neo 400, 1 additional weight 15 kg, disc holder for 12 diamond segments, hearing protection, operating manual, spare parts list, spirit level, without grinding segments

Accessories:

Extension cable	#15960
Brush below for suction ring	#84810
Additional weight complete	#72225
Stabiliser wheel	#83702

DIAMOND SEGMENTS FOR SPECIAL APPLICATIONS. ALL SEGMENTS SUITABLE FOR MONODISC GRINDING MACHINES UP TO 1500 RPM

ES diamond segments for preparing screed

For grinding and removing sintered layers of screed and for removing thin paint layers on soft mineral substrates.

Diamond segment SC 20	#56306	Diamond segment SC 60	#56309
Diamond segment SC 40	#56308		



BT diamond segments for preparing concrete substrates

For grinding concrete, coatings and high-grade compounds and for removing thin paint layers on hard substrates.

Diamond segment SS 20	#48038	Diamond segment SS 60	#56303
Diamond segment SS 40	#48041		



PCD diamond segment

For aggressive removal of polyurethane varnishes, compounds and tile adhesives.

Not suitable for rolled asphalt screeds.

PKD-segment	#48028
-------------	--------



PCD splinter diamond segments

For removing thin epoxy resin layers, paint, synthetic resin, polyurethane and dispersion adhesives.

Suitable for removing fleece backing and textile double backing. Not suitable for soft screeds.

PCD splinter segment	#48036
----------------------	--------



Conversion kit for diamond grinding plates delivered up to 04/2008

For diamond grinding plates delivered up to 04/08 when the above listed segments are used (5 sets are required normally). Includes: Segment holder complete with mounting elements

Conversion kit for diamond grinding disc	#48957
--	--------

Includes: Segment holder with mounting elements



PCD Scraper XT

Segment with 5 straight PCD, but without support segment. For extreme hard residues of levelling compounds, adhesives and coatings. More aggressive, especially for removing thick layers

PCD Scraper XT	#75366
----------------	--------



PCD Ultra

Segment with 5 straight PCD and support segment. For medium-hard to hard smoothing compounds, adhesive residues and coatings

PCD Ultra	#75364
-----------	--------



PCD Ultra XT

Segment with 5 straight PCD, but without support segment. For medium-hard to hard smoothing compounds, adhesive residues and coating. More aggressive, especially for higher layer thicknesses

PCD Ultra XT	#75365
--------------	--------



PCD viper

Segment with three pointed PKDs, with support. For removing highly tempered (extremely hard) smoothing compounds. Recommended use for the NEO 400

PCD viper	#10831
-----------	--------



PCD viper XT

Segment with three pointed PKDs without support. For removing highly tempered (extremely hard) smoothing compounds. For aggressive removal. Recommended use for the NEO 400

PCD viper XT	#10832
--------------	--------



CT 200

Floor milling machine with a wide range of applications

- Ideal for small to medium-sized areas
- 2.0 kW consumption
- Variable tool insert



#13641 - 230V (EU)

Floor milling machine CT 200

- for everything from removing residues to heavy milling jobs
- handy and compact machine for heavy-duty use
- precise adjustment of milling depth
- industrial vacuum cleaner connection for low dust extraction

Technical specifications:

Voltage 230 V, power: 2 kW, working width 200 mm,
 Dimensions 97 x 80 x 36 cm (H x L x W), weight 52 kg,
 Area output 10 - 30 m²/h (strongly dependent on the condition of the substrate,
 the type of tool used and the infeed depth of the machine),
 Suction connection 50 mm

Includes:

Floor milling machine CT 200, hearing protection,
 without milling drum

Accessories:

Shafts for milling drum CT 200, set of 4 pcs.	#13646
Extension cable WOLFF, 25 m (EU plug)	#41811
Starting current limiter, external	#13639

Milling drum CT 200 with milling blades

To roughen concrete. To remove old residues of adhesive, compounds or paint on hard, solid substrates!

Not to be used on free floating screed

Milling drum CT 200 with milling blades	#13642
Milling blade set for CT 200, 76 pcs.	#13643
Intermediate disc set for milling drum CT 200, 76 pcs.	#13644

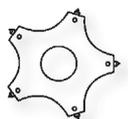

Milling drum CT 200 complete with peeling blades

To remove old residues of adhesive, compounds or coatings
 on soft substrates and floating screeds

Milling drum CT 200 complete with peeling blades	#13648
Peeling blade set for CT 200, 40 pcs., 10 mm	#13649
Intermediate disc set for peeling blade drum CT 200, 72 pcs.	#13650

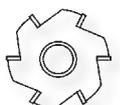

Milling drum CT 200 complete with star-shaped blades

To remove thin paint layers and roughen metal surfaces

Milling drum CT 200 complete with star-shaped blades	#38923
Star-shaped blade set for CT 200, 356 pcs.	#38924
Milling drum CT 200 (not shown) without blades	#13645



SCREED JOINT CUTTER EF EF 135

Screed joint cutter for fast and dust-free cutting of cementitious substrates

Allows dust-reduced cutting and efficient work progress

Variable depth adjustment

Very handy

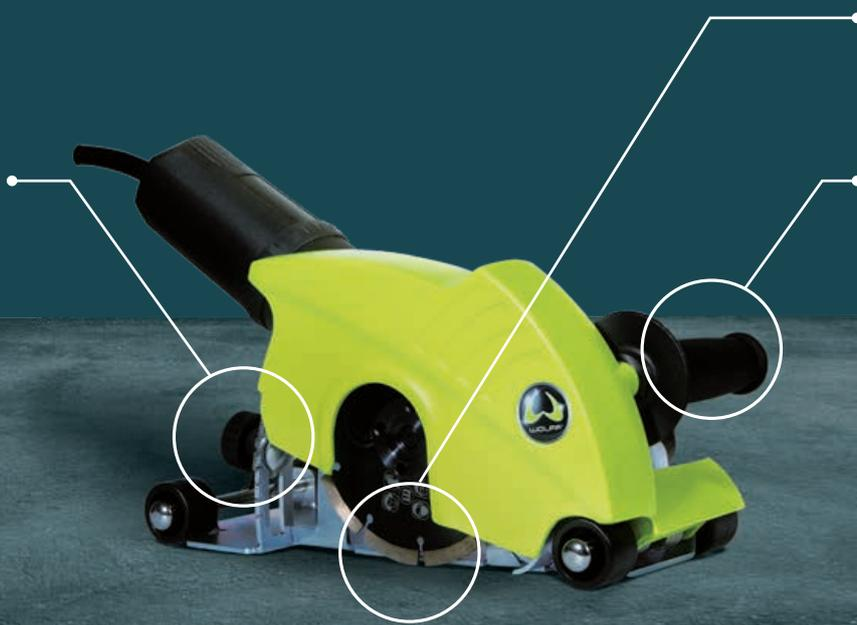

#68679 - 230V (EU)

Screed joint cutter EF 135

#81340 - 115V (UK)

Tool for time-saving and dust reduced cutting of cementitious substrates. Ideal for stress induced joints and expansion joints. The perfect solution for clean, precise and efficient working.

- cutting depth up to 35 mm
- variable depth adjustment
- cutting disc guide
- very versatile
- efficient dust extraction
- rollers allow convenient cutting

Technical specifications:

230 V/115 V, 1,550 W, 11,000 rpm, cutting depth 35 mm, weight approx. 5 kg

Includes:

Screed joint cutter EF 135, DIA cutting disc Ø 135, connecting piece for industrial vacuum cleaner, protective goggles, hearing protection, tool kit

Accessories:

DIA cutting blade Ø 135 (standard)	#68602
Carrying case	#84759
Wave connector PU 1,000 pcs.	#13932
Wave connector PU 100 pcs.	#13878



STARVAC MI55

Compact and powerful vacuum cleaner for wet and dry cleaning



#60800 - 230V (EU) Starvac MI55

- fully automatic filter cleaning through patented system
- variable speed control
- fully electrically conductive system including electrically conductive suction hose (4 m)
- casters, suction hose and extra flexible electric cable (7.5 m)
- dust class M
- manually adjustable suction power

Technical specifications:

Mains voltage 220 - 240 V, max. power 1380 W, (H x W x L) 580 x 380 x 870 mm, Weight 17.5 kg, inlet 35 mm, hose length 4 m (antistatic and non-chalking), Air volume max. 140 m³/h, vacuum max. 22.00 kPa, tank capacity 54 l

Accessories:

Suction wand	#60944
Suction hose, 4 m	#60951
Floor nozzle	#60947
Aluminium floor nozzle, 370 mm	#62162
Crevice nozzle	#60950
Filter bags (5 pcs.)	#60948
Wet and dry vacuum cleaner filter	#61933
Dry vacuum cleaner filter	#60949
Starvac disposal bags (10 pcs.)	#62697
Membrane filter	#62562

Includes:

Starvac MI55, suction hose (4m), suction hose, paper filter bag, wet/dry floor nozzle 300 mm, crevice nozzle, connecting piece for power tools (3 pcs.), drainage hose, 54 L container

POWERFUL PRE-SEPARATORS

Separation of coarse dirt and fine dust

- Powerful and constant suction power
- Particle separation rate up to 99%
- Suitable for most electrical machines



#72916

Pre-separator 30 l

Powerful pre-separator, which can filter out large amounts of coarse dirt and fine dust, even before vacuuming. It is suitable for floor milling and grinding machines, saws, hand grinders and many other machines. It can also be used for vacuuming surfaces with a floor nozzle.

- constant suction power
- vacuum cleaner and filter are protected
- particle separation rate up to 99%
- non-marking wheels
- easy disposal using standard rubbish bags

Technical specifications:

weight: 8.9 kg, size: Ø 36 x 83 cm, hose length: 1.2 m, capacity 30 l

Includes:

Cyclone separator completely assembled, dirt container, hose 1.2 m (#73102)

Application note:

The pre-separator is connected between the vacuum cleaner and machine

#82215

Pre-separator antistatic – especially for wooden dust 50 l

Powerful pre-separator which can filter out large amounts of coarse dirt and fine dust even before vacuuming.

- constant suction power
- protection of vacuum cleaner and filter
- separation efficiency up to 99% of the particles
- easy emptying with standard garbage bags
- static conductive hose and cyclone
- due to static conductivity especially suitable for wooden dusts
- suction hose and end connection adapted for WOLFF Starvac and Vacuclean (adapter set for Ronda #82069)

Technical specifications:

weight: 10 kg, size Ø 40 x 92 cm, hose length 1.5 m, capacity 50 l

Includes:

Cyclone completely assembled, dirt container, hose 1.5 m (#82202)

Application note:

The pre-separator is connected between the vacuum cleaner and machine

VACUCLEAN 2

High-performance industrial vacuum cleaner for coarse dirt and dust

Semi-automatic filter cleaning

Large surface area

Very robust PU hose

Dirt can be removed quickly

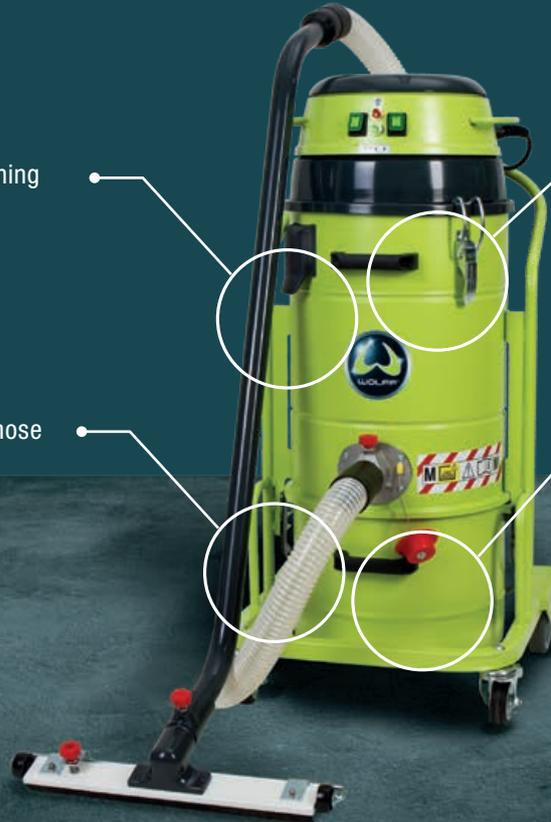

#81148 - 230V (EU)

VACUCLEAN 2

#83574 - 115V (UK)

High-performance industrial vacuum cleaner for coarse dirt and dust with a large filter surface area.

- large cartridge filter with 2 m² filter surface area (dust class M)
- semi-automatic and highly efficient filter cleaning system using powerful air blasts for a long service life
- the vacuum display allows you to continuously monitor whether the appliance is functionally perfectly and to detect possible clogging of the filter
- dirt can be removed quickly, safely and hygienically using the lever emptying function on the mobile collection container
- a HEPA filter is available as an optional accessory

Technical specifications:

Supply voltage 230 V/115 V, power 2,300 W, (L x W x H) 590 x 480 x 1,010 mm, Weight 35 kg, hose length 5 m, air volume 360 m³/h, negative pressure 25 kPa, Filter category Main filter M, tank capacity 20 l

Includes:

Vacuclean 2, reducing piece 50/38, 5 meter PU-hose 50 mm, suction tube, floor nozzle 430 mm

Accessories:

Connection piece 50 mm	#81990
Floor nozzle 38 mm	#81618
Flat nozzle	#83178
Reducer	#81626
Suction tube	#81620
Hose connector	#13338
Replacement hose 5 m	#13337
Replacement brush for floor nozzle 430 mm	#83446
Standard filter class M	#81613
Filter PTFE	#81615
Filter H14 / HEPA	#81616
Cone nozzle	#81627

Vacuclean 2 HEPA (230V EU)

#82452

VACUCLEAN 2 LP

High-performance industrial vacuum cleaner with Longopac system



#81149 - 230V (EU)

VACUCLEAN 2 LP

#83727 - 115V (UK)

#81706 - 115V (US)

High-performance industrial vacuum cleaner Vacuclean 2 with Longopac system for removing coarse dirt and dust reliably and safely. With a lift function to lower the suction unit to facilitate transport of the appliance.

- large cartridge filter with 2 m² filter surface area (dust class M)
- features two individually switchable 1,150 watt motors
- semi-automatic and highly efficient filter cleaning system using powerful air blasts for a long service life
- the vacuum display allows you to continuously monitor whether the appliance is functionally perfectly and to detect possible clogging of the filter
- lift function to lower the suction unit
- 22 m endless dust bag

Technical specifications:

Supply voltage 230 V, 115 V power 2,300 W, (L x W x H) 590 x 480 x 1,200 mm, Weight 38 kg, hose length 5 m, air volume 360 m³/h, negative pressure 25 kPa, Filter category Main filter M

Includes:

Vacuclean 2 LP, reducing piece 50/38, 5 meter PU-hose (50 mm diameter), suction tube, floor nozzle 430 mm, endless hose, cable clip (#81628)

Accessories:

Connection piece 50 mm	#81990
Floor nozzle 38 mm	#81618
Flat nozzle	#83178
Reducer	#81626
Suction tube	#81620
Hose connector	#13338
Replacement hose 5 m	#13337
Replacement brush for floor nozzle 430 mm	#83446
Endless dust bag (4 x 22 m)	#81629
Cable ties	#81628
Standard filter class M	#81613
Filter PTFE	#81615
Filter H14 / HEPA	#84681
Cone nozzle	#81627
Vacuclean 2 LP HEPA (230V EU)	#82453

T-REX

Powerful industrial vacuum cleaner
for coarse dirt and fine dust

- Vacuums coarse dirt
- 3.5 kW consumption
- Accessories can be selected individually
- With improved hose quality



#13314 - 230V (EU) **T-REX**

#80071 - 115V (UK)

Powerful industrial vacuum cleaner with three motors for coarse dirt and fine particulars.

- vacuums coarse dirt, pieces of debris or fine dust from grinding
- manual shaking unit for easy cleaning of the fabric filter
- 50 litre dirt container can be removed and emptied easily
- the industrial vacuum cleaner comes on rugged running gear with large wheels for convenient mobility
- works effectively and powerfully with a hose length of up to 15 m

Technical specifications:

230 V/115 V, 3,500 W, 50 l container, air suction capacity 570 m³/h, suction power 2,200 mm H₂O, filter surface 3 m², weight 65 kg, power cord 10 m, dimensions 58 x 60 x 125 cm

Includes:

Vacuum cleaner T-Rex, fine dust filter, starter set

Customise your vacuum cleaner using different sets!

Accessories

Starter set (consisting of)	#40066
Suction hose, 50 mm, length 5 m	#13337
Suction wand 50 mm T-Rex	#13335
Roller nozzle T-Rex	#13336
TS 40/T-Rex 50 mm end fitting	#13339
T-Rex 50 mm connecting piece	#13340
Hose clamp, 40 – 60 mm	#13445
T-Rex suction nozzle, round	#14262
Hose connection 50 mm	#13338

Spare filter

T-Rex absolute filter (HEPA)	#51152
Fine dust filter	#14261

Connecting kit, 50 mm consisting of:

- TS 40/T-Rex, diameter 50 mm end fitting	#13339
- T-Rex 50 mm connecting piece	#13340
- Hose clamp, 40 – 60 mm	#13445

Hose kit, 70 mm, consisting of:

- Suction hose, 70 mm diameter, (15 m)	#48371
- 70 mm end fitting	#14273
- 70 mm diameter connecting piece (T40 & T-Rex)	#14268
- Hose clamp, 60 – 80 mm	#14269
- Connecting adapter 70/50	#61802

Brush set roller nozzle	#56026
-------------------------	--------

T-Rex 70 mm add-on nozzle consisting of:

Add-on nozzle brush set	#14264
Add-on nozzle rubber lip	#14265

AIR CLEANER LR 690

Dust class H



- Cleaning of the ambient air during renovation and deconstruction work
- Prevents the dust from spreading into additional rooms
- Easy to transport

#10057 - 230V (EU)

Air cleaner LR 690

- cleaning of the ambient air during renovation and deconstruction work
- dangerous, respirable fine dusts are filtered by means of coarse filter mats and H-filters
- the use as a vacuum unit (by means of dust doors) prevents the dust from spreading into additional rooms
- dust can be filtered/extracted directly at the point of origin
- automatic volume flow monitoring
- the negative pressure can be adjusted by a rotary switch and thus adapted to the requirements on the construction site
- low working noise
- compact design
- easy to transport due to low weight of 6.0 kg
- dust class H

Accessories

Pre-filter mats G3, 340 x 405 mm (10 pcs.)	#10515
HEPA H14 Filter, 620 m ³ < 330 Pa	#10519
Coarse filter G4, 1100 m ³ < 45 Pa	#10516
Compact air hose, 125 mm diameter / 6 m length, black	#10513
Compact air hose, 205 mm diameter/ 7.5 m length, black	#10587
Air hose connection adapter 205 mm diameter	#10509
Transparent exhaust air hose 125 mm diameter x 0.15 mm, 88 meters	#10514
Cover plate for dust formation during mixing	#10511
Dust door 2.3 m x 1.3 m, 0.14 mm	#84246



PREPARING SUBFLOORS



STIRRING | SMOOTHING

Mixer Power X 1000

1,010 Watt 1- speed gear mixer

#83924 -
230V (EU)

- robust 1-speed gear unit
- ergonomic handle
- M14 thread
- mixing fluid mortar (e.g. levelling compounds)

Technical specifications:

230 V, 1,010 W, 0–780 rpm, thread M14, max. diameter for mixer: 120 mm, weight: 4.5 kg

Includes:

Power X 1000, Mixer Type KR 120 S/M14

Accessories:

Extension 200 mm (EU plug)

#68353



From 06/20 available
as a battery-powered
device



Mixer Power X 1600

1,600 Watt 2-speed-transmission with adjustable speed.

#84169 -
230V (EU)

- robust 2-speed gear unit
- 1600 W 2-speed transmission with 3 steps
- ergonomic handle on drive unit
- solid-shaft electronics: soft-start, temperature control, overload protection
- for mixing fluid and viscous mortar (e.g. levelling compounds)
- perfect for mixing big containers up to 75 kg (in combination with WOLFF stirring station 75 l)
- combined mixer for floor layers
- M14 thread

Technical specifications:

230V, 1,600 W, idle speed, 1. gear: 210/325/530 rpm, idle speed 2. gear 320/490/780 rpm, M14 thread, max. diameter for mixer: 160 mm, weight ca. 5 kg

Includes:

Power X 1600, mixer Type KR 140 S/M14

Accessories:

Extension 200 mm (EU plug)

#68353



Extension

200 mm (EU plug)

#68353



Stirrer, MK type

Rugged professional stirrer with long service life. 3 mixing wings for fast mixing.

Great mixing from bottom to top. Machine pod with M14 thread.

Stirrer Typ MK 120 mm

#13604

Stirrer Typ MK 160 mm

#13611



Stirrer, KR type

Easy to clean. Suitable for very viscous adhesives or seals and gypsiferous or bituminous materials.

Ideal for smoothing compounds as it prevents clotting.

Stirrer, type KE 90S

#13605

Stirrer, type KE 120S

#13606

Stirrer, type KE 120S (M14 thread)

#17057

Stirrer, type KR - 140

#39364



30 l transportation caddy including mixing bucket

To mix up to 30 kg of powder products. #65846

- 2-stop tip system for perfect balance
- suitable for all common 30 l buckets

Includes:

Transportation caddy base frame, 30 l mixing bucket

Accessories:

Transportation caddy base frame	#65848
30 l mixing bucket	#65847
Pouring spouts (10 pcs.)	#15829



Stirring station, 75 l, complete

Complete stirring station to mix up to 75 kg of powder products #65480

- 2-stop tip system for perfect balance
- perfectly matched tools
- suitable for all types of stirring machine thanks to special mounting

Includes:

Base frame, mixing bucket 75 l, mounting, stirrer for stirring station, hose holder

Accessories:

75 l stirring station base frame	#65481
75 l stirring station mounting	#65491
75 l stirring station stirrer	#65492
75 l stirring station mixing bucket	#65493
75 l stirring station hose holder	#65494



Stirrer for 75 l stirring station

Large double-wing stirrer to mix up to 75 kg of powder products #65492



Mixing bucket 110 l

New enlarged mixing bucket with a capacity of 110 litres.

For mixing light screeds #83248

Accessories:

Mixer Type MK 160 mm	#13611
----------------------	--------



OneMix

The OneMix is suitable for mixing wood adhesive, epoxy resin primer and epoxy resin mortar.

The stirring discs (attachments) are intended for one-time stirring.

Only the rod is cleaned after mixing, the stirring attachments can be thrown away.

OneMix stirring rod	#87946
OneMix stirring attachments (10 pcs.)	#87947



Ripper

Helps reduce dust when opening levelling compounds.
To clip on the 30 l WOLFF mixing bucket.

#84094



Swiss trowel

500 mm

#56204



Adhesive trowel

With a 280 mm insert

#56205



Smoothing trowel

280 x 135 mm

#56203



Grinding stone

To grind compounds and screed.

Abrasive stone with handle. Dimensions: 20 x 10 x 3.5

#13493



HM grinding stone

For rough grinding or to remove residues. Contains hard metal splinter for aggressive use.

Angled work surface for grinding along walls.

HM grinding stone, grit 24

#15718



FLOW-FIX-SET



#84137 Flow-Fix-Set

Allows for quick and ergonomic deployment of levelling compounds onto the floor.

- can be installed on the mixing bucket with the drill provided
- in combination with the WOLFF Caddy, the levelling compound in the mixing bucket can be emptied easily and precisely
- ideal for WOLFF mixing bucket 30 l (#65847)

Includes:

Flow-Fix, hand drill

WATER DOSING DEVICE



Illustration shows water dosing unit with stand (available as a accessory).

#84917 - 230V (EU) Water dosing device

Simple and quick dosing of a defined amount of water when mixing screeds / levelling compounds. Ideal for mixing large quantities.

Includes:

Water dosing device, transportation case, two water connections (compatible with the Gardena-connection), 230 V power supply

Technical data:

Unit: Litre, measuring range: 0.05 – 9999.99 Litres, power supply: AC/DC Adapt 100 – 240 Volt, 50/60 Hz Power supply, water pressure: min. 0.2 – max. 4 bar, Water connection: brass tap piece ½" 21 mm (compatible with Gardena connector system)

Accessories:

Tripod	#84920
Hose set	#85963



Tripod



Hose set

Adhesive interchangeable spatula, 28 cm with handle

- to apply adhesive while standing
- special hinge imitates movement of the hand
- easy to clean thanks to special design

#65495

Includes:

Universal telescopic handle, adhesive interchangeable spatula, handle bracket

Accessories:

Replacement smoothing compound rake

#65496

Universal telescopic handle

#65497

Handle bracket

#67983



Smoothing compound rake, 56 cm with handle

- to apply smoothing compounds while standing
- special hinge imitates movement of the hand
- easy to clean thanks to special design

#65501

Includes:

Universal telescopic handle, smoothing compound rake, handle bracket

Accessories:

Replacement smoothing compound rake

#65502

Universal telescopic handle

#65497

Handle bracket

#67983



Large area rake, 60 cm with handle

- to apply smoothing compounds while standing
- adjustable pins for height adjustment
- special hinge imitates movement of the hand

#65503

Includes:

Universal telescopic handle, large area rake, handle bracket

Accessories:

Replacement large area rake

#65504

Universal telescopic handle

#65497

Replacement pins for large area rake, 1 pair

#65505

Handle bracket

#67983



Universal telescopic handle

- to work ergonomically while standing
- suitable for various attachments
- can also be used with spike rollers with special adapter
- adjustable length from 97 cm up to 170 cm

#65497

Includes:

Universal telescopic handle, large area rake, handle bracket

Accessories:

Adapter for spike rollers

#65499



Roller bracket for telescopic handle

Allows the use of rollers with universal telescopic handle.

Roller bracket for telescopic handle

#87948



Handle holder for rake

Allows use of the telescopic handle (#65497) for rake, pin rake and pin leveller (see picture above).

Handle holder for rake (joint less)

#87949



#52298



#13658



#79742



handle holder
for rake
(joint less)

Spike rollers

For ventilating compounds and coatings.

Splash guard included.

Working width:	25 cm	50 cm	75 cm
Pin length, 11 mm	#13879	#13762	#14270
Pin length, 21 mm	#14272	#14021	#14271
Pin length, 31 mm	#13637	#13636	#13638
Pin length, 100 mm (without splash protection cap)	–	#88320	–

Accessories:

Universal telescopic handle (shown on page 57)	#65497
Adapter for universal telescopic handle (shown on page 57)	#65499



Rake

To apply smoothing compounds. Mount for wooden handle to work while standing.

Working width, 56 cm. Rake insert with R2 notch included. Adhesive notch, 56 cm, 10 pcs.	#52298
R1 notch	#13397
R2 notch	#13396
R3 notch	#51546



Pin rake

To apply smoothing and levelling compounds and coatings. Allows working in an upright position. Width 600 mm, with 4 pins and stainless steel blade for level adjustment to any application depth between 0 and 10 mm. Includes stick holder, without stick.

Pin rake	#79742
----------	--------



Pin leveller

With mounting sleeve for handle or telescopic pole, angular steel mounting piece with exchangeable steel blade, 100 mm high, 0.6 mm thick, 2 adjustable pins for level adjustment to any application depth between 6 and 30 mm.

Working width 800 mm

Pin leveller	#13658
Steel blade	#13659
Spare pins, 2 pcs.	#13660



Universal holder

Holder made of powder-coated square steel tube, aluminium socket for handle made of wood or metal, metal fixing strip with 5 wing screws. Suitable for rubber strips (see page 59)

Universal holder	#87890
------------------	--------



Rubber strips for universal holder (shown on page 58)

Rubber strips made of light rubber in Shore A 60, smooth or serrated.

Dimensions (LxH) 650x55 mm.

Rubber strips – serration 0 mm (smooth)	#87895
Rubber strips – serration 2 mm	#87896
Rubber strips – serration 3 mm	#87897
Rubber strips – serration 4 mm	#87898
Rubber strips – serration 5 mm	#87899
Rubber strips – serration 8 mm	#87901
Rubber strips – serration 14 mm	#87902

**Nylon roller, 250 mm**

For applying floor adhesives, bituminous coatings, polyester coatings, two-component varnishes and acidproof coatings. Extremely rugged and solvent resistant. **Without roller handle.**

Nylon roller	#13763
Roller handle	#15551

**Super fine foam roller, 250 mm**

For applying varnishes and coatings; suitable for synthetic enamels, acrylates, primers and prevarnishes. CFC-free polyester foam. **Without roller handle.**

Super fine foam roller	#15552
Roller handle	#15551

**Roller container**

For storing used application rollers.

Effectively prevents the roller drying out.

Roller container	#41789
------------------	--------



Ergostar spatula - the No. 1!

- ergonomic, resilient grip
- no rivets used to fix the grip channel, allowing for easier cleaning

Ergostar spatula, 21 cm	#41784
Ergostar spatula, 28 cm	#41787



Interchangeable spatula

For use with WOLFF adhesive notches.

Interchangeable spatula, 21 cm	#13378
Interchangeable spatula, 28 cm	#13381



Adhesive spatula

Working width:	18 cm	25 cm
Adhesive spatula, A1 notch	#13761	#15569
Adhesive spatula, A2 notch	#13876	#13886
Adhesive spatula, B1 notch	#13877	#13841
Adhesive spatula, B2 notch	#15566	#15570
Adhesive spatula, B3 notch	#15567	#15571
Adhesive spatula, B11 notch	#38622	#39923
Adhesive spatula, w/o notch	#15568	#15572



Solid board notched trowel

Special notched trowel with B11 notches and 2 raised notches	#65656
--	--------



Height levelling spatula

Made of 0.7 mm thick, 115 mm wide, hardened and highly polished stainless spring band steel and 40 mm high wooden handle. The height stop edge, fixed with 2 lock screws and wing nuts, is adjustable from 2 to 15 mm.

Height levelling spatula stainless steel 280 mm	#87889
---	--------



Sample collection

WOLFF adhesive notches in accordance with TKB	#51771
---	--------



Plasterer spatula

Made of polished stainless steel. Spotted stainless steel tang.
Handle: ergonomically shaped 2-component plastic.

Plasterer spatula - width 80 mm	#87879
Plasterer spatula - width 100 mm	#87880



Serrated coating spatula

With hardened and finely flexibly ground and polished steel blade (toothed with B1 TKB profile).
The waxed wooden handle (beech) is riveted throughout.

Serrated coating spatula – width 60 mm	#87881
Serrated coating spatula – width 80 mm	#87882



Floor spatula

Made of 0.6 mm thick, hardened and polished steel with an oblique wooden handle. Width: 530 mm

Floor spatula 530 mm	#87884
----------------------	--------



Rapid spatula, stainless steel

Made of 0.3 mm thick, hardened and stainless spring steel strip. Slightly curved at the working edge,
100 mm visible blade height. With adjustable blade and 35 mm wide waxed wooden handle.

Rapid spatula (stainless steel) 200 mm	#87877
Rapid spatula (stainless steel) 270 mm	#87878



NOTCH SELECTOR

WOLFF adhesive notches, double sided, in accordance with the TKB „Technical Commission on Construction Adhesives“ (10 pcs., delivered in a plastic box)								
Image in original size	TKB					Width 21 cm	Width 28 cm	Width 56 cm
	A1	0.50	1.50	1.10	55°	#13367	#13382	–
	A2	1.30	1.70	1.40	55°	#13373	#13388	–
	A3	0.40	1.60	1.50	45°	#13374	#13389	–
	A4	0.40	1.10	0.75	55°	#13375	#13390	–
	A5	1.45	1.35	1.00	55°	#13376	#13391	–
	B1	2.60	2.40	2.00	55°	#13370	#13385	–
	B2	2.00	3.00	2.55	55°	#13371	#13386	–
	B3	3.30	3.70	3.25	55°	#13372	#13387	–
	B9	9.90	6.10	5.00	60°	–	#33754	–
	B11	7.90	6.10	5.00	60°	#13380	#13399	–
	R1	1.50	4.00	3.00	–	#13400	#13402	#13397
	R2	2.00	4.00	5.00	–	#13401	#13403	#13396
	R3	2.40	5.00	6.00	–	–	–	#51546
	S2	0.10	4.20	3.35	60°	#13404	#13410	–
	S3	0.10	2.50	1.75	65°	#13409	#13413	–

Levelpin

Self-adhesive height-measurement markers for levelling compounds and screeds. 10 x 10 pcs.

#80040



Nail shoes

For walking on coated or filled substrates and surfaces

Nail shoes

#51549

Includes:

Nail shoes, set of spare nails, 2 spare straps #53091



Nail shoes Spiky

For walking on coated or filled substrates and surfaces

Nail shoes Spiky size M, for size 42 (8) and smaller

#80454

Nail shoes Spiky size L, for size 42 (8) – 44 (10)

#80455

Nail shoes Spiky size XL, for size 44 (10) – 48 (15)

#80456

Spare nails Spiky (packaging unit 32 pieces)

#80457

Spare nails round (packaging unit 32 pieces)

#83464



Copper band

For applying conductive flooring. To discharge electrostatic charge.

Roll 50 m (width: 10 mm)

#13594

Roll 200 m (width: 10 mm)

#13595

Roll 2 x 25 m, self-adhesive roll (width: 10 mm)

#54874



Corrugated links

To fix down flexible joints and repair cracks in the subfloor. For friction-based sealing of expansion joints, e.g. with UZIN KR516. 70 mm long, 2 mm wide.

Corrugated link, 1,000 pcs.

#13932

Corrugated link, 1,000 pcs.

#13878



MEASURING INSTRUMENTS



MEASURING DEVICES | TEST KIT

#71053

Universal hygrometer V1-D4 Professional

- designed for moisture measurement of subfloors
- non-invasive moisture test method with high measuring accuracy
- easy to use
- real-time display of measurements on easy to read display
- suitable for preliminary checks to determine the dryness of materials for CM and RH measurements
- RF-Measurement possible by additional air sensor

Constraints:

Moisture Meter VI-D4 does not detect concrete humidity through electricity conducting materials like metal coverings/ linings, PE-rubber or any wet surfaces. It should not be used to measure concrete humidity on covered surfaces.

Technical specifications:

Dimensions: 147 x 89 x 33 mm, power supply: battery supply, 2 x AA 1.5 Volt, display: black-white with background lighting, resolution 128 x 64 pixel, operating temperature range from 5°C to 40°C, accuracy: $\pm 0.5\%$, available scales: concrete, carbide method, relative scale and 15.3 Scale, IR surface temperature sensor

Includes:

Measuring instrument V1-D4 Professional, batteries, case

UNIVERSAL HYGROMETER V1-D4 PROFESSIONAL



UNIVERSAL HYGROMETER V1-D4 BASIC

#83113

Universal hygrometer V1-D4 Basic

- basic version of the Hygrometer V1-D4
- for technical details see selector on page 68

Constraints:

see V1-D4 Professional

Technical specifications:

Dimensions: 147 x 89 x 33 mm, power supply: battery supply, 2 x AA 1.5 Volt, display: black-white with background lighting, resolution 128 x 64 pixel, operating temperature range from 5°C to 40°C, accuracy: $\pm 0.5\%$, available scales: concrete, carbide method, relative scale, 15.3 scale. Without IR surface temperature sensor.

Includes:

Hygrometer V1-D4 Basic, batteries, case



ACCESSORIES HYGROMETER UNIVERSAL V1-D4 PROFESSIONAL

Brush electrodes set BE-03

For measuring screed moisture over 2 holes

#73618



Flat electrodes set FE-04

Can be introduced to edge insulation strips, for detecting moisture under the floating screed

#73619



Pinhead measuring electrode PP-05

For the moisture measurement of wood

#73772



Air sensor with cable CS-06

For the determination of temperature, humidity and dew point

#73773



Air sensor with cable CS-10

For the determination of temperature, humidity and dew point.
Remains in the borehole. Is delivered with #73775

#83665



Sealable sleeve for air sensor

Locking device for the borehole to measure the relative humidity in concrete
(RFT/KRL method) unit 20 pcs.

#73775



Resistor measured sample (Set) CE-07

For measuring resistance and measuring conductivity

#73774



Thermohygrometer LVT 15 Professional

- can be used for measurements of the air temperature, the surface temperature and the relative humidity (RH)
- calculates the dew point
- also features a connection for the thermocouple (type K) for additional measurement of the surface temperature
- visual and acoustic alarm when temperature changes between the surface temperature and material temperature occur
- technical details see selector on page 69

#71055

Technical specifications:

Power supply: battery supply, 2 x AA 1.5 Volt, current consumption: 34 mA, dimensions: 146 x 79 x 26 mm (H×W×D), display: monochrome with background lighting, resolution 128 x 64 pixel, operating temperature range from 5°C – 40°C, < 80% of relative humidity without condensation

Includes:

Measuring instrument LVT 15, batteries, case, surface probe OF-02

Accessories:

Submersible probe TF-01

#71056



Thermohygrometer LVT 15 IR

- measurement of air temperature and relative humidity
- calculation of the dew point
- surface temperature measurement without additional sensor due to the built-in infrared sensor
- visual and audible alarm at temperature differences
- for technical details see selector p. 69

#83115

Technical specifications:

Power supply: battery supply, 2 x AA 1.5 Volt, current consumption: 34 mA, dimensions: 146 x 79 x 26 mm (H×W×D) display: monochrome with background lighting, resolution 128 x 64 pixel operating, temperature range from 5°C – 40°C, < 80% of relative humidity without condensation, with built-in infrared sensor.

Includes:

Thermohygrometer LVT 15 IR, batteries, case



Moisture meter GM-200

- for measuring moisture of concrete, gypsum, cement
- moisture measurement of wood
- non-invasive moisture measurement
- compact and ergonomic design with non-slip rubber grip
- quick and convenient measurement due to adjustable display orientation
- custom alarm limit, with acoustic signal

#71054

Technical specifications:

Dimensions: 142 x 79 x 24 mm, power supply: battery supply, 2 x AA 1.5 Volt, display: monochrome, with 128x63 pixel resolution and background lighting, display orientation, operating temperature from 5°C to 40°C, 9 measuring scales

Includes:

Measuring instrument GM-200, batteries, case



HYGROMETER-SELECTOR



#83113



#71053

MEASURING RANGE

	V1-D4 BASIC	V1-D4 PROFESSIONAL
Concrete, mass, weight %	0–6.0 Gew.-%	0–6.0 Gew.-%
Cement CM %	0–4 CM-%	0–4 CM-%
Cement weight in %	0-6 weight %	0-6 weight %
Anhydrite CM %	0–1.9 CM-%	0–1.9 CM-%
Anhydrite weight in %	0-6 weight %	0-6 weight %
Relative humidity scale	0–100 %	0–100 %
IR surface temperature sensor	–	-30–+250 °C
15.3 scale/digits	0.3–15.3	0.3–15.3

MEASURING SCALES

Concrete mass weight %	●	●
Cement CM %	●	●
Cement weight in %	●	●
Anhydrite CM %	●	●
Anhydrite weight in %	●	●
Relative scale	●	●
15,3 scale/digits	●	●
IR temperature sensor	–	●
Wood moisture by wood type	–	●
Resistance measurement Ohm scale	–	●

CONNECTIONS

3.5 mm jack connection	–	●
Mini USB port connection	–	●

EQUIPMENT

#73618 Brush electrode set BE-03	–	●
#73619 Flat electrode set FE-04	–	●
#73772 Impact electrode PP-05	–	●
#73773 Climate sensor CS-06 with cable	–	●
#83665 Climate sensor CS-10 with cable	–	●
#73775 Hose for climate sensor	–	●
#73774 Set for resistance measurement	–	●

Includes

Measuring device V1-D4	●	●
Battery pack	●	●
Case	●	●
Instruction manual	●	●

THERMOHYGROMETER SELECTOR



#83115



#71055

MEASURING RANGE	LVT 15 IR	LVT 15 PROFESSIONAL
Air temperature	-10 – +50 °C	-10 – +50 °C
Humidity	5 – 99 %	5 – 99 %
Dew point	-30 – +100 °C	-30 – +100 °C
IR surface temperature sensor	-30 – +250 °C	–
Surface probe OF-02	–	●
Submersible probe TF-01	–	OPTIONAL
ACCESSORIES		
#71056 Submersible probe TF-01	–	●
Includes		
Measuring instrument LVT 15	●	●
Surface probe OF-02 (#71057)	–	●
Batteries	●	●
Case	●	●
Operating instruction	●	●

Substrate test kit

Contains all the equipment needed to test substrates and carry out all moisture tests in preparation for CCM measurement.

#79320

1. Thermohygrometer LVT15 IR (see page 67)

The LVT 15 can be used for measurements of the air temperature, the surface temperature and the relative humidity (RH) as well as to calculate the dew point.

2. Screed moisture indicator GM-200 (see on page 67)

For measurement of moisture content of screed, gypsum, cement, EPS and wood.

3. Scratcher

Set consists of scratcher, scratch template and protective bag.

4. Measuring wedge

To measure the lowest point between 2 support points of the straightedge.

Measuring wedge can be read from above.

5. Practical accessories

Hammer and wire brush.

Includes:

Systainer, thermohygrometer LVT 15 IR, screed moisture indicator GM-200, scratcher, hammer, measuring wedge, wire brush.



Measuring wedge

To measure the lowest point between 2 support points of the straightedge.

Measuring wedge can be read from above

#13628



Subfloor strength tester

Using the scratch method, parallel lines are scratched into the floor at an angle of 40-60°.

The scratched grid and the torn-out parts of the floor are used to assess the strength of the floor

#13803

Includes:

Tester, scratch template, protective bag



CCM device classic

Complete set with all instruments required to measure the moisture content.

#13486

Comes with metal carrying case

Includes:

Lump hammer 1000 g, hammer, flat chisel, sampling spoon short, cleaning brush, mechanical sample scale up to 100 g, ball set with 4 steel balls, grinding bowl, 2 sample cups with lid, set of sundries with seals, calibration ampoules, set of 25 carbide ampoules, calibrated standard pressure bottle with surface thermometer, weighing bar for precision spring scales, mechanical manometer up to 2.5 bar, stopwatch, aluminium case



CCM Set ECO

CCM Set ECO

#65431

Includes:

Lump hammer 1000 g, flat chisel, sampling spoon short, cleaning brush, digital sample scale up to 200 g, ball set with 4 steel balls, grinding bowl, 2 sample cups with lid, set of sundries with seals, calibration ampoules, set of 25 carbide ampoules, calibrated standard pressure bottle with surface thermometer, weighing bar for precision spring scales, ECO manometer up to 1.6 bar with lid, metal case

CCM Set Alu Business Pro

Complete set in blue aluminium case, including log printer

#84546

Includes:

Lump hammer 1000 g, hammer, flat chisel, sampling spoon short, cleaning brush, digital sample scale up to 200 g, ball set with 4 steel balls, grinding bowl, 2 sample cups with lid, set of sundries with seals, calibration ampoules, set of 25 carbide ampoules, calibrated standard pressure bottle with surface thermometer, digital manometer up to 3 bar, log printer, aluminium case



Accessories for all CCM-instruments:

Carbide phials 25 pcs.	#74554	Seal rings (3 small + 3 large rings)	#15872
Carbide phials 100 pcs.	#13662	Ball set, 4 pcs.	#14019
CM pressure gauge	#15874	Smashing bowl	#18372
Digital CM pressure gauge	#15876	Digital scale	#16256
Test phials, 10 pcs.	#14020	Spring scale	#15873

PressoMess shear strength measuring instrument

Special measuring instrument for assessors and reviewers from the flooring industry

#16273

To measure the shear strength of substrates, such as screed, compounds and wooden material.

- shear strength is measured with a hydraulic sensor
- shear strength can be read off the display
- tested by the Materials Testing Institute at the University of Stuttgart (MPA Stuttgart, Otto Graf Institute (FMIPA))
- max. test load 5 kN

Includes:

PressoMess, distance template, hand-held spatula, mixed adhesive, 20 pairs of wooden blocks, carrying case

Accessories:

Supporting blocks, 100 pcs.	#13922
Test blocks, 100 pcs.	#13923
Mixed adhesive	#13926



HMBOX

Moisture Measurement 4.0

- High cost savings
- Permanent measurement
- Less time on the construction site
- Non-destructive, clean and simple
- Mobile data availability via browser and app
- Monitoring & fast response for many users



#85860

hmbox

The hmbox is easy to handle and determines the humidity of different building materials, such as screeds, without damaging the subfloor. The moisture can be determined in a user-friendly and non-destructive way by applying it once to the substrate. With the hmbox numerous data is collected and transmitted via GSM to a central server and stored there. The aluminium ring of the hmbox is fixed with glue to the floor. In the cavity of the alu-ring the sensors measure the corresponding relative humidity and the temperature of the material. Sensors in the housing measure the temperature and relative humidity of the room. The hmbox determines the right time for the installation of floor covering regardless of the subfloor.

Includes:

hmbox, 1 x hm glue, 1 x cutter knife, 1 x can for quick test, carrying case, 1 x screwdrivers, instruction manual

- for the purposes of the customer, an accurate and non-destructive measuring method allows to determine the humidity of different materials.
- the data and test results are transmitted digitally and can be read using a web browser or viewed with an APP by different users (owner, architect, construction manager, etc.)

Accessories:

hm glue

#85861

PAINT-CHECKER



LASER-DISTANCE-ANALYSER PT 400



#84761 Paint-Checker

A device to analyse colours and match colours against standardised colour ranges. The results show the two colours closest to the chosen colour range, as well as the RGB percentage.

Analysis for the following colour ranges:

- RAL Effect, RAL Design & RAL Classic
- Pantone
- NCS
- PPG Chromatic
- PPG Voice of Colours
- Caparol 3D System
- SIKKENS 5051

Includes:

Paint-Checker, batteries, plastic case

#84428 Laser-Distance-Analyser PT 400

- suitable for measuring distances, surfaces, as well as volume and Pythagoras calculations
- single and permanent measurements
- measuring range: 0.05 - 40 m (measuring distance up to 40 m)
- small and compact

Includes:

Laser-Distance- Analyser, battery, carrying bag, hand loop

THE WOLFF 18V RANGE

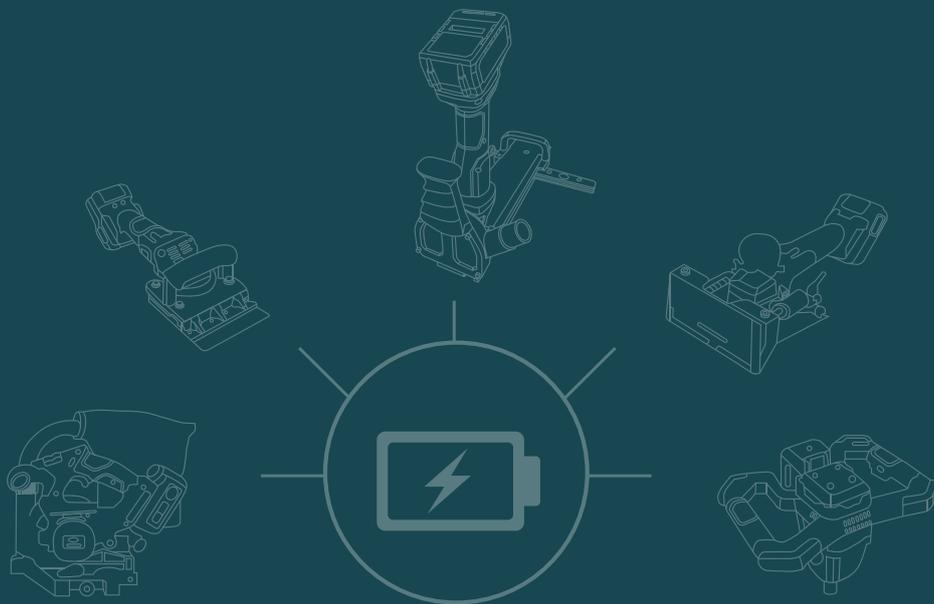

POWERFULL PERFORMANCE WITHOUT CABLES

JUNIO-STRIPPER 18V

Floor removal for small areas

- With transport case
- Robust device
- Light and handy



- #10327 **Junio-Stripper 18V only**
- #10328 **Junio-Stripper 18V set EU**
- #10329 **Junio-Stripper 18V set UK**
- #10334 **Junio-Stripper 18V set USA**

Removal of textile coverings, foam, adhesive residues and glass fibre wall coverings within small areas.

- enables work in difficult places such as window recesses or under radiators
- effective for stairs and walls
- includes transport case

Technical data:

Battery voltage: 18V, Battery capacity: 5Ah, Working width: 120 / 200 mm, Weight without battery: 2.9 kg, Hand/arm vibrations: 12.5 m/s², Speed: 8,500 rpm

The sets include:

Junio-Stripper 18V, 2x 18V 5Ah-battery, charger, replacement blade, leather knife protection, transport case, open-end wrench

Battery and charger for 18V-range

Replacement battery 18V 5Ah (1 piece)	#10930
Charger 230V EU	#10939
Charger 230V UK	#11772
Charger 115V USA	#11770

CORDLESS MIXER POWER X 18V

Battery powered 2-gear mixer

— Powerful and mobile

Fully compatible
battery pack



**AVAILABLE FROM
06 2020**

- #10415 **Cordless Mixer Power X 18V only**
- #10440 **Cordless Mixer Power X 18V set EU**
- #10442 **Cordless Mixer Power X 18V set UK, 230V charger**
- #10443 **Cordless Mixer Power X 18V set US, 115V charger**

Battery powered, 2-speed mixer that can be used in areas without mains power

- for mixing smoothing compounds and coatings
- for mixing up to 30 kg
- robust 2-speed gearbox for powerful speed control with 3 adjustable speeds
- comfortable 3-step switch accessible from the handle without interrupting work, step 1: clean, step 2: stir, step 3: stir
- motor speed regulation for soft start, temperature monitoring and overload protection
- ergonomic handles
- for M14 attachments

Technical data:

Voltage: 18V, Battery capacity: 5Ah, Adjustable maximum speed 1st gear: 210/325/530 rpm, Adjustable maximum speed 2nd gear: 320/490/780 rpm, Tool holder M14, Max. diameter for stirrer 120 mm, Weight: approx. 5 kg

Includes:

Power X 18V, stirrer Type KR 120 S/M14
The sets: Power X 18V, 2 x 18V 5Ah battery, charger, stirrer type KR 120 S/M14

Battery and charger for 18V-range

Replacement battery 18V 5Ah (1 piece)	#10930
Charger 230V EU	#10939
Charger 230V UK	#11772
Charger 115V USA	#11770

STRIP CUTTER LS35 / LS65 18V

For lino, vinyl and rubber

— Ideal for difficult to cut material

Fully compatible
battery pack



#10339

Strip cutter LS 35 18V only

#10318

Strip cutter LS 65 18V only

Battery-driven strip cutter for lino, vinyl and rubber

- for the production of plinth strips, flooring friezes and stair coverings
- ideal for difficult to cut material

Technical data LS35 18V:

Battery voltage: 18V, Battery capacity: 5Ah, Working width LS35: 3-35 cm,
Speed: 8,500 rpm, Weight without battery LS 35: 5.8 kg

Technical data LS65 18V:

Battery voltage: 18V, Battery capacity: 5Ah, Working width LS65: 3-65 cm,
Speed: 8,500 rpm, Weight without battery LS 65: 6.2 kg

The sets include:

LS 35/ LS 65, 2 x 18V 5Ah battery, charger, saw blade with diameter 105 mm, tool kit, safety goggles, hearing protection, transport case, dust bag

Sets

LS 35 18V set EU (with EU 230V charger)	#10344
LS 35 18V set UK (with UK 230V charger)	#15662
LS 35 18V set USA (with US 115V charger)	#10322
LS 65 18V set EU (with EU 230V charger)	#10319
LS 65 18V set UK (with UK 230V charger)	#10346
LS 65 18V set USA (with US 115V charger)	#10347

Battery and charger for 18V-range

Replacement battery 18V 5Ah (1 piece)	#10930
Charger 230V EU	#10939
Charger 230V UK	#11772
Charger 115V USA	#11770

MASTERGROOVER 18V

Very compact grooving machine with unlimited mobility

- Automatic depth control
- Ensures full grooving even on uneven surfaces



#89660

Mastergroover 18V only

#89000

Mastergroover 18V set EU

#89663

Mastergroover 18V set UK

#89664

Mastergroover 18V set USA

Very compact grooving machine with unlimited mobility due to battery operation.

- automatic depth control guarantees full grooving even on uneven surfaces.
- with adjustable guiding wheel, e.g. for studded rubber
- low-dust operation due to improved extraction
- rotatable dust pipe
- easy adjustment of the milling depth up to 7 mm - even on very uneven ground

Technical data:

Battery voltage 18V, Battery capacity 5Ah, Speed 5,000 rpm, Milling depth 7 mm, Milling blade 3.5 mm elliptical, 12 teeth, 130 mm diameter, Weight without battery 4.5 kg

The sets include:

Mastergroover 18V, 1 x 18V-battery with 5Ah, charger, HM saw blade elliptical with 130 mm diameter, allen key, dust bag, transport case incl. inlay

Sets/Accessories

HM saw blade 130x20x3,5 elliptical (standard)	#89623
HM Saw blade 130x20x2,8 round	#89625
PCD saw blade 130x20x3,8 conical	#89658

Battery and charger for 18V-range

Replacement battery 18V 5Ah (1 piece)	#10930
Charger 230V EU	#10939
Charger 230V UK	#11772
Charger 115V USA	#11770

PIRANHA 18V

For precise cutting of doors

- The HM saw blade with 54 teeth achieves a perfect clean cut
- Height and depth adjustable

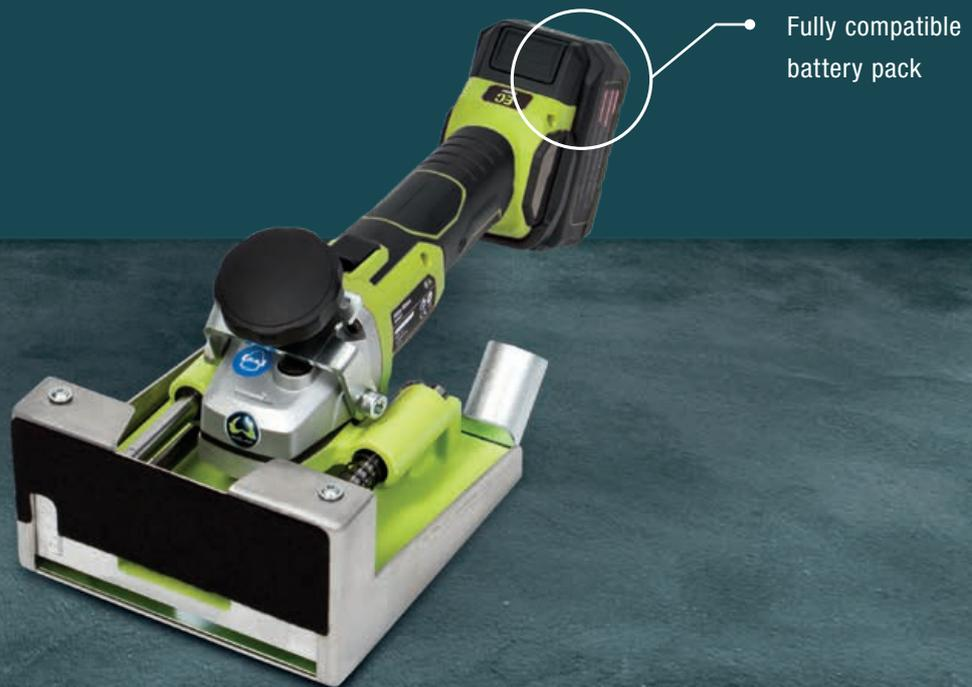

#10287

Piranha 18V only

#10289

Piranha 18V set EU

#10290

Piranha 18V set UK

#10294

Piranha 18V set USA

For precise cutting of doors, door frames and skirting in situ. Can also be used for cutting wood and laminate floors after installation. The HM saw blade with 54 teeth achieves a perfect, clean cut.

- variable height and depth adjustment: height 25 mm, depth 50 mm
- HM saw blade for a long service life
- 8500 rpm

Technical data:

Battery voltage 18V, Battery capacity 5Ah, Saw depth: 0-45 mm, Saw height: 7-25 mm, Suction connection: 32 mm, Speed: 8,500 rpm, carbide saw blade with 165 mm diameter and 54 teeth, Weight without battery: 5.0 kg

The sets include:

Piranha 18V, 2 x 18V battery 5Ah, charger, HM-saw blade with 165 mm diameter, allen key, dust bag, transport case incl. inlay

Battery and charger for 18V-range

Replacement battery 18V 5Ah (1 piece)	#10930
Charger 230V EU	#10939
Charger 230V UK	#11772
Charger 115V USA	#11770

APPLYING FLOORS



**LINOLEUM | VINYL | RUBBER |
TEXTILE FLOORS | MILLING | WELDING**

LINOCUT

The original!

- Simple, ergonomic handling
- Includes 2 base plates for more versatility
- With depth stop

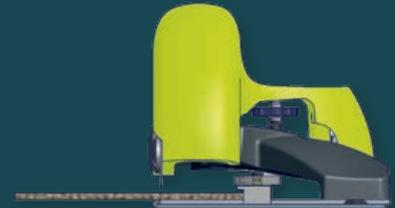

Base plate for removing factory cut edges #13449



Base plate for reverse cutting #60676

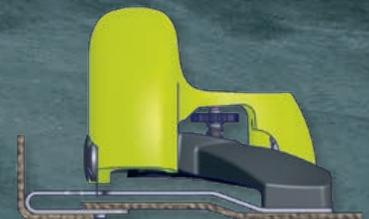

For scribing resilient floor coverings up to skirting #60676

#40262

Linocut seam cutter

Improvement on a classic tool. Perfect seams for all resilient and needle punch floor coverings. Different base plates for a range of applications!

- patented technology
- excellent design
- straight cut without straight edge
- ergonomic handle for easy use
- cuts from wall to wall
- two blades to cut in both directions
- cuts the top edge and uses the bottom edge as guide
- can be used on material placed into wet adhesive
- extremely safe
- seam width and depth can be easily adjusted

Includes:

Linocut, standard base metal sheet 2 mm guide, base for needle punch carpet 4 mm guide, 10 spare blades (2 already mounted)

Accessories:

Spare blades, 10 pcs.	#13429
Base plates for additional applications:	
Standard base 2 mm guide	#13430
Carpet base 8 mm guide	#13432
Needle punch base 4 mm guide	#13431
Base plate for removing factory-cut edges	#13449
The edge cutting width can be adjusted from 1.5 - 6 cm in three steps. Suitable for all versions of the Linocut.	
Base plate for reverse cutting	#60676
To use the Linocut as a reverse cutter for scribing resilient floor coverings up to PVC skirting. Suitable for all versions of the Linocut.	

GREENCUT

Practical multi-purpose device

- Includes 2 bases for more versatility
- With depth stop
- Suitable for right and left-handed users



#63998

Greencut

- for cutting seams
- for neat trimming of factory-cut edges
- includes 2 bases for needle punch and resilient floor coverings
- all-metal construction
- suitable for right and lefthanded users

Includes:

Greencut seam and edge cutter, 4 mm guide, 2 mm guide, 3 feeders (5 mm, 10 mm, 15 mm), spacer, 10 hooked blades, 10 straight blades



Base plates and inserts

Accessories

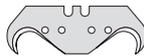
Straight blades (100 pcs.)		#13419
Hooked blades (100 pcs.)		#13421
Super hook blade (100 pcs.)		#13422

RAILCUT

Perfect seam cutting

- For perfect seam cutting
- Height-adjustable blade
- Practical and ergonomic



#69864

Railcut

WOLFF Railcut is for perfect seam cutting. The seam cut is made using a rail at the ideal angle of 90° to the floor covering.

- create a perfect seam for resilient floor coverings for example, rubber and vinyl as well as soft textile coverings
- also usable as strip cutter
- height-adjustable blade (0 – 15 mm)
- practical and ergonomic shape for comfort
- 1.40 m anti-slip rail
- rail can be extended
- suitable for right and left handed users

Includes:

Railcut, 1.40 m anti-slip rail, 10 straight blades

Accessories:

Spare rail with connector (1.40 m)

#69877

Straight blades (100 pcs.)

#13419

DESIGN COLLECTION

The complete set for installing design floors and LVT

- The best tools for installing design floors and LVT
- Proven thousands of times
- In useful Tanos carrying case
- Now including Pica-dry marker!



#74843

Design Collection

The complete set for installing design floors and luxury vinyl tiles. Comes with practical Tanos carrying case for an easy and safe transportation.

- perfect seams
- chamfering the back of the flooring
- duo pressure roller to press the seam
- easy and safe transportation in Tanos carrying case

Includes:

Linocut seam cutter, FasTrimmer for chamfering the floor backing, Duo pressure roller, Pica-Dry marker, mitrebox shears for design floor, carrying case

Accessories:

Tanos carrying case

#74844

Strip cutter

For cutting strips, e.g. PVC skirting, stairs, borders and factorycut edges.

For 0 - 8 cm strips	#13350
For 3 - 20 cm strips	#13351
For 6 - 30 cm strips	#13352

Accessories:

Spare blades, 5 pairs	#13353
Web, 5 pcs.	#13947
Conversion kit, to use hooked blade	#13354
Hooked blades, 100 pcs.	#13421

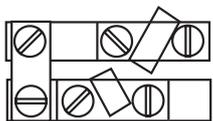

Arrangement of blades for simultaneous scribing and cutting

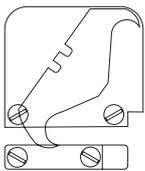

Conversion kit for use of hook blades

Electric strip cutter for linoleum and PVC

LS 35 (35 cm cutting width)	#15661 - 230V (EU)
LS 65 (65 cm cutting width)	#16148 - 230V (EU)

Ideal for cutting heavy or thick material.

For cutting PVC skirting, stairs, borders and factorycut edges.

Technical specifications:

1.01 kW, 10,000 rpm, HM saw blade, max. strip width 35 cm / 65 cm, max. material thickness 6 mm

Includes:

LS 35/LS 65, tool kit, protective goggles, hearing protection, dust bag

Accessories:

Saw blade	#15662
-----------	--------

ALSO AVAILABLE AS A 18V BATTERY POWERED OPTION

See Page 77



Linoleum edge cutter

For trimming the factorycut edge to remove stress along seams or transportation damage

#15605

Includes:

Linoleum edge cutter, 2 blades

Accessories:

Spare blades, 5 pcs.

#13358



Circular cutter

WOLFF circular cutter and scribe for resilient, textile, laminate and solid wood flooring

#15626

For precise cutting or scribing of circles and circle segments with a diameter of up to 260 cm - over 12 m with extension rails.

- precise, reproducible circles
- fixed with suction cups
- quick radius adjustment
- scribing or cutting
- exact depth adjustment of the blade
- with knurled screw
- smallest radius 160 mm

Includes:

Professional circular cutter, Plexiglass disc with adhesive strips, extension rails up to 130 cm radius, pencil, spare blades, carrying case

Accessories:

Spare blades, 6 pcs.

#15625

Extension rails up to 4.86 m radius

#15629

Adapter for corner and wall radius. To create a circle segment centred on a wall corner or a point along a wall

#15631

Joint groover for circular cutter

#15628

Spare blade

#13427



Hole cutter

For drilling holes for heating pipes, line pipes and stair railings when laying design coverings, LVT, PVC linoleum, laminate and wood. Now also available with drill attachment of 16–30.5 mm

Hole cutter - diameter 8–20 mm

#15807

Hole cutter - diameter 16–30.5 mm

#87831



MULTI-SPIDER

Precise adjustment of door frames, heating pipes, curves, etc.

- For all corner cut-outs, also diagonal.
- Precise adjustment of door frames, heating pipes, curves, etc.
- Suitable for laying designer floors, LCT, wood, laminate and tiles.



#87919

Multi-spider

Includes:

1 x base plate 450 mm, 2 x Tastarm 250 mm, 2 x Tastarm 350 mm,
4 x clamping slides, 4 x push-button pointed/pointed

Accessories:

Base support 450 mm	#87920
Base support 200 mm	#87921
Clamping slide	#87922
Base link	#87923
Measuring arm 250 mm	#87924
Measuring arm 350 mm	#87925
Measuring arm 550 mm	#87926
Probe pointed/pointed	#87927
Probe round/round	#87930
Probe pointed outside	#87931
Probe pointed inside	#87932



picture shows
Multi-spider with accessories
(optional)

DESIGN CUTTER WO 330

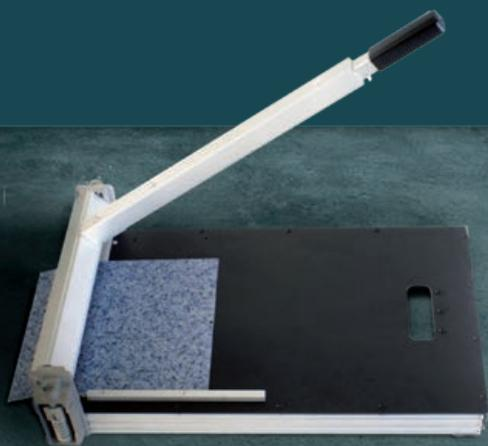

#72661

Design Cutter WO 330

- fast and precise
- quiet and dust-free
- portable and light weight

Technical specifications:

Blade width 330 mm, max. material thickness 16 mm,
max. object width 320 mm, assembled size 650 x 460 x 500 mm, weight 9.34 kg

Accessories:

Spare blade for WO 330

#72752

DESIGN CUTTER WO 630



#72663

Design Cutter WO 630

- fast and accurate
- quiet and dust-free
- portable

Technical specifications:

Blade width 630 mm, max. material thickness 16 mm, max. object width 630 mm,
assembled size 520 x 740 x 520 mm, weight 18.8 kg

Accessories

Spare blade for WO 630

#72776

PRESSURE ROLLERS FOR FLOORING



Pressure rollers for flooring

- #56401 Pressure roller 30 kg
- #56402 Pressure roller 50 kg
- #56403 Pressure roller 68 kg

With carrying handles for more convenient transportation.

- each roller consists of 4 rollers that adjust perfectly to the floor
- the extremely narrow spaces between the rollers avoid blistering

Includes:

Pressure roller, handle

Accessories:

Wheels for transportation

#56404

Pressure roller for floor coverings

- ideal for rolling all types of floor coverings within small to medium-sized areas
- the rollers adapt to uneven floors
- the surface pressure can be changed by the user
- can be used for right and left handed users

size: 1.35 x 0.47 x 0.15 m; weight: 5.2 kg

Pressure roller for floor coverings

#15834



Rubbing device

- lightweight, handy tool for rubbing floor coverings, especially for stairs and edges
- rounded edges: no scratches of wall and floor coverings
- suitable for edges with 45° and 90°

Rubbing device

#83734



Duo pressure roller

For rolling the seam of resilient and textile floor coverings into the adhesive.

Duo pressure roller

#73709



Glide with removable felt coat and handle

Lightweight glide for convenient operation while standing.

Ideal for textile and resilient floor coverings. 40 cm width, zinc plated.

Glide with removable felt coat and handle

#62694

Includes:

Glide with handle, felt coat

Accessories:

Felt coat for glide

#61201



Rubbing hammer

Forged in a single piece

Rubbing hammer

#13619



Cork rubbing board

30 x 12 x 2.5 cm

#60505



FasTrimmer

To create a chamfered edge of 25° to the surfaces of LVTs and design floor coverings after they have been cut. Comes with a base for fast chamfering on the surface and backing of design floor coverings

#15621

Includes:

FasTrimmer, base, carrying bag, 6 spare blades

Accessories:

Base for chamfering the floor backing of PVC tiles and design floors as well as removing rough edges

#15622

Spare blades, 10 pcs.

#80578



FasTrimmer

Comes with a base for chamfering floor backings and cleaning rough edges.

#15623

Includes:

FasTrimmer, base for chamfering floor backing, carrying bag, 6 spare blades

Accessories:

Spare blades, 10 pcs.

#80578



Combi scriber

For scribing and cutting resilient floor coverings.

Can be used as scriber and reverse scriber.

#13357

Includes:

Combi scriber, 2 scriber needles for linoleum and 2 pointed blades for PVC and rubber (in the handle)

Accessories:

Scriber needles, 20 pcs.

#13356

Spare blades, 5 pcs.

#13358



Seam scriber

For scribing resilient floor coverings. Adjustable scriber needle

#13355

Accessories:

Scriber needles, 20 pcs.

#13356



Stair scriber

For scribing stair flooring

#15620

Accessories:

Scriber needles, 20 pcs.

#13356



Combined floor covering scriber and cutter

For scribing and cutting along walls. Continuously adjustable. Can also be used as a circle scriber and cutter

Includes:

Combined floor covering scriber and cutter - Adjustment range 385 mm

#87911

Accessories:

Spare blades, 6 pcs.

#88329



Marker pins

Marking pin, length 45 mm, pack of 25 pcs.

#87913



FRÄSMASTER

Joint grooving machine Fräsmaster. The No. 1!

- Automatic depth control
- Electronic speed control
- Can be used on very uneven substrates

ALSO AVAILABLE AS A 18V BATTERY POWERED OPTION

See page 78



Example of automatic depth control

#13305 - 230V (EU)

Grooving Machine Fräsmaster

#15711 - 115V (UK)

#50159 - 115V (US)

- automatic depth control to ensure full grooving of joints even on uneven substrates
- comes with adjustable guiding wheel, e.g. for grooving studded rubber floors
- faster and more powerful thanks to improved power transmission
- improved extraction for low dust emission
- hand guard when machine is raised to prevent accidents
- easily changeable grooving discs
- simple setting of grooving depth up to 5 mm
- 3 wheels for stability
- floor surface will not be damaged as the grooving disc recesses automatically when the handle is lifted
- integrated electronic starting current limiter for a soft start

Technical specifications:

230V/115 V, 1,500 W, 6,000 - 10,000 rpm, soft start, semicircular HM grooving disc 3.3 mm, 12 teeth, diameter 130 mm

Includes:

Fräsmaster, HM grooving disc 3.3 mm, tool kit, dust bag, protective goggles, hearing protection, Systainer box

Accessories

HM milling blade Ø 130 x 3.8 elliptical 12 teeth	#13459
HM milling blade Ø 130 x 5.0 elliptical 12 teeth	#13461
Diamond milling blade Ø 130 x 3.8 elliptical 4 teeth	#13460
Round HM grooving disc, 130 x 20 x 3,3 mm, 12 teeth	#21208

FRÄSJUNIOR

For grooving all types of resilient flooring

- Up to a depth of 5 mm
- Excellent extraction
- Versatile



#56092 - 230V (EU)

Grooving machine Fräsjunior

For grooving all types of resilient flooring

- easy grooving setup up to a depth of 5 mm
- perfect three-point support
- clean start using the dive-in principle
- improved extraction

Technical specifications:

230 V, 1,500 W, 8,000 rpm, semicircular HM grooving disc 3.3 mm, 12 teeth, diameter 130 mm

Includes:

Fräsjunior, HM grooving disc 3.3 mm, tool kit, dust bag, protective goggles, hearing protection, Systainer box

Accessories

HM milling blade 130 X 20 X 3.8 elliptical, Z12	#13459
Combi grooving disc, 5 mm	#13461
Diamond milling blade elliptical 130 x 3.8, Z4	#13460
Semicircular HM grooving disc, 3.3 mm	#21208

REPAIR-GROOVING MACHINE

For safe and precise grooving of welding cords and fusion wires.

- Grooving width 6 mm
- Precise settings
- Perfect milling of old welds



Example of automatic depth control



#76859 - 230V (EU) Repair-grooving machine

For safe and precise grooving of welding cords and fusion wires.

- for the repairing defective welds
- grooving width 6 mm
- automatic depth control to ensure full grooving of joints even on uneven substrates
- for further machine description, see Fräsmaster

Technical specifications:

230 V, 1,500 W, 6,000 – 10,000 rpm, grooving disc 130 x 6 mm, suction device 30 mm, max. grooving depth 0 - 5 mm

Includes:

Repair-grooving machine, HM grooving disc 130 x 20 x 6 straight Z6, Systainer, tool kit, dust bag, protective goggles, hearing protection

Accessories:

HM milling blade Ø 130 x 9.0 6 teeth

#76860

Joint groover with guiding wheels

Two small wheels to guide along the seam. Adjustable groove depth, 4 grooving blades. #73710

Accessories:

Spare blade #13427



Groover

Adjustable guide, 4 grooving blades #13426

Accessories:

Spare blades, 10 Pcs. #13427



Groover for rubber floors

Groover for rubber floors (u-shape) #13842

Accessories:

Spare blades U-shape, 10 pcs. #13843



Joint groover J-shape

joint groover J-shape #87914

Accessories:

Spare blades J-shape, 10 pcs. #87915



Joint groover with guiding pin

Adjustable groove depth #13424

Accessories:

Spare blades, 10 pcs. #13425

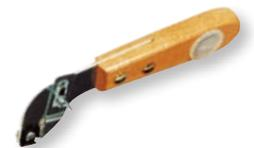

Seam trimmer

For trimming welded seams to inside and outside corners. #13485

Includes:

Seam trimmer, 1 round blade 6 mm

Accessories:

Round blade, 6 mm #13813

Round blade, 12 mm #13868

Flat blade #13870



Welding rod roller

To press the weld rod into the joint. #15610

Welding rod roller, 15 mm #15611



AUTOMATIC WELDING MACHINE WELDMASTER

Fully automatic solution for all requirements

- Digital temperature control
- Robust and compact design
- Best welding results



#56255 - 230V (EU)

#56259 - 115V (UK)

#56260 - 115V (US)

Automatic welding machine Weldmaster

The WOLFF automatic welding machine has a special nozzle for PUR floors to avoid thermal shock or burns.

- digital thermometer for precise temperature control
- central key pad for easy operation
- can be used for all resilient floor coverings (PVC, linoleum, polyolefin, rubber)
- variable surface pressure for improved welding results
- 4 welding nozzles for even hot air distribution
- rugged and compact machine
- automatic wall cutoff with lifting device: this diverts the hot air to the side nozzles to prevent thermal shock and burns

Includes:

Automatic welding machine, carrying case

Technical specifications:

Materials: PVC, linoleum, polyolefin, rubber, speed 1.7-5.8 m/min, voltage 230 V/115 V, total consumption 3.1 kW, Temperature 20-600 °C, weight 14 kg

Accessories:

Heating element, 3.0 kW

#13480

GROOVING AND WELDING SET

The perfect set for beginners



#56357 - 230V (EU)

Grooving and welding set

#60865 - 115V (US)

We have created a set which is unique on the market especially for flooring contractors who lay small or medium-sized resilient flooring coverings

Includes:

- joint grooving machine Fräsjunior
- the hand-operated welding machine Phoenix 1600
- a quarter moon knife with safety sheath
- a weld seam slide
- a single nozzle 5 mm
- a quick welding nozzle 5 mm
- carrying case

PHOENIX 1600

Hand welding with proven quality

- Adjustable temperature
- Heating tube protection for more security
- Easy-to-clean air filter



PHOENIX 1600 SET

Hand operated welding machine Phoenix 1600 with comprehensive accessories in useful Systainer box.



#80078 - 230V (EU)

Phoenix 1600

#80081 - 115V (UK)

Hand operated welding machine

- heating tube protection for more security
- easy-to-clean air filter
- Adjustable temperature 40°C-700°C

Technical specifications:

230 V/115 V, 1.6 kW, continuously adjustable temperature 40°C-700°C

Includes:

Phoenix 1600, single nozzle 5 mm, speed welding nozzle 5 mm, in carrying case

Accessories:

Heating element Phoenix 1.6 kW 230 V	#80355
Heating element Phoenix 1.6 kW 115 V	#80307
Speed welding nozzle PUR 5 mm	#41213

#80614 - 230V (EU)

Phoenix 1600 Set

#82890 - 115V (UK)

Hand operated welding machine Phoenix 1600 with comprehensive accessories in useful Systainer box.

Technical specifications:

230 V/115 V, 1600 W, continuously adjustable temperature 40°C-700°C

Includes:

Phoenix 1600, single nozzle 5 mm, speed welding nozzle 5 mm for polyolefin, joint groover, diamond grindstone, quarter moon knife, weld seam slide, pressure roller 15 mm, cleaning brush, in Systainer box

JOINTING

Leister Triac Set ST

Hand-operated Triac ST welding machine with electronic control and cooled protection tube.
Case includes comprehensive accessories. Comes with diamond grindstone to sharpen quarter moon knives.

#74847 -
230V (EU)

Technical specifications:

230 V, total consumption 1.6 kW, heating element 1.55 kW, temperature 20-650°C

Includes:

Triac ST, single nozzle 5 mm, speed welding nozzle 5 mm for polyolefin, joint groover, diamond grindstone, quarter moon knife, weld seam slide, pressure roller 15 mm, cleaning brush, in Systainer box



Leister Triac ST Successor of the Leister Triac S

Hand-operated welding machine, separate, as described in the set

#74845 -
230V (EU)

Accessories:

Heating element 1.55 kW for Triac ST

#72315

Speed welding nozzle

#13308



Leister Triac Set AT

Hand-operated Triac AT as a complete kit.
Comes with diamond grindstone to sharpen quarter moon knives.

#82643 -
230V (EU)

Technical specifications:

230 V, total consumption 1.6 kW, heating element 1.55 kW, temperature 20-650°C

Includes:

Triac AT, single nozzle 5 mm, speed welding nozzle 5 mm for polyolefin, joint groover, diamond grindstone, quarter moon knife, weld seam slide, pressure roller 15 mm, cleaning brush, in Systainer box



Leister Triac AT

Leister Triac AT, single nozzle round 5 mm

#71991 -
230V (EU)

- The set temperature reaches its level automatically, voltage fluctuations are compensated.
- Quick clean air filters
- Automatic carbon stop and heating element protection provide automatic protective measures
- Functional design: two-component handle and optimum center of gravity ensure good ergonomics
- Suitable for all jobsites

Accessories:

Heating element Triac AT

#72315

Speed welding nozzle

#13308



Leister Electron ST

Leister Electron ST, without nozzle. For heating vinyl floor coverings and skirting boards.

#76769 -
230V (EU)

Technical specifications:

Heating element 3.3 kW, temperature 20-650 °C

Accessories:

Heating element, 3.3 kW

#13475

Round nozzle

#13476



ACCESSORIES FOR HAND WELDING MACHINES

PUR welding nozzle

Burns on the floor surface are definitely a thing of the past!

Special nozzle for thermal welding and jointing of resilient floor coverings which have a factory-applied polyurethane coating. Eliminates scorch and burn marks

#47049



Single nozzle

5 mm

#13465



Speed welding nozzle

5 mm

#13308



Speed welding nozzle for polyolefin

Inlet 4 mm

#13466

Inlet 5 mm

#41213



Correction nozzle

Inlet 4 mm

#13469



Mipolam nozzle

„Mipolam“ jet-nozzle

#13467

Accessories:

Welding rod roll, 25 mm

#15610

Welding rod roll, 15 mm

#15611



Gooseneck nozzle

Gooseneck nozzle

#13468



Radiator nozzle

Radiator nozzle

#13470



Broad nozzle

20 mm

#19524

20 mm, angled

#13472

40 mm

#13473



Speed welding nozzle

For PVC wall coverings

#13471



KNIVES FOR APPLYING FLOORS

Mozart Speed Trimmer

The Mozart speed trimmer can primary remove excess weld from seam whilst standing.
The cutting procedure, blades and slides are the same as the Mozart push-off knife.
The slide can be adjusted.

#62183

Includes:

Mozart Speed Trimmer, complete, with blade and 0.5 and 0.7 mm slides, boxed, telescopic handle



Mozart trimming knife

The universal solution for quickly , cleanly and safely removing the excess weld from the seam. Inte-
grated slide for precutting, exchangeable blade, exchangeable slides for variable heights. Ellminates
scratching and damaging surfaces. Internal cutting edge.

#49875

Includes:

Trimming knife with blade and 0.50 mm slide

Accessories:

Spare blades, 5 pcs.

#49876

Slider, 0.50 mm

#50772

Slider, 0.70 mm

#51270

Spare screw set

#59856



Quarter moon knife

To remove the weld rod. Excellent quality.

#13451



Quarter moon knife

To remove the weld rod, angled

#13452



Quarter moon knife

To remove the weld rod, bent

#13453



Weld seam slide

For primary removal of the weld rod

#13450



Safety sheath

Leather, for quarter moon knife

#60078



Diamond grindstone

For regrinding of all blades. Grinding surface 153 x 50 mm.

#13491



Diamond grindstone

For sharpening. Collapsible, fits any bag, grinding surface 110 x 22 mm

#15714



SKIRTING BOARDS AND FORM COVES

WOLFF Wallmaster

Special tool to install skirting boards and form coves

#60890

- height is clearly marked
- mitre joints on internal and external corners can be cut easily and accurately
- the corners of floor coverings are levelled and pressed down evenly without the risk of damaging the floor covering

Accessories:

WOLFF Wallmaster straight edge

#61394



WOLFF Wallmaster is recommended by:



Installation instructions:



Day 1

Before installing: Apply a heat-activated adhesive (recommendation UZIN DK 290) with a B1 notch.



Day 2 (Step 1)

Install the floor covering over the desired skirting height. Fold back the PVC floor covering and apply a suitable adhesive (UZIN KE 66 recommended) with a A2 notch. Lay the covering into the adhesive and rub in. Heat the floor covering in the skirting area from behind with the Leister Electron.



Day 2 (Step 2)

After heating, use the WOLFF Wallmaster to fit the covering into the inner corners.



Day 2 (Step 3)

Cutting the mitre using the WOLFF Wallmaster as a guide. Then reactivate the thermal adhesive (UZIN DK 290) with the Leister Electron.



Day 2 (Step 4)

Press the floor covering into the corners and along the wall with the Wallmaster.



Day 3 (Step 5)

On day 3 thermal weld the seams on the floor and in the corner.

TOOLS FOR LAYING TEXTILE FLOOR COVERINGS

Carpet cutter

Carpet cutter specially designed for woven and tufted fine velours.

The extremely fine guiding pin is accurate even in very tight stitch lines

#65659

Includes:

Carpet cutter, slot hole blades

Accessories:

Slot hole blades (10 pcs.)

#65755

Recommended by:

GIRLOON **INFLOOR**
carpet-fashion



Carpet awl

For optimum guidance along the stitch line

#65660

Recommended by:

GIRLOON **INFLOOR**
carpet-fashion



Mittag cutter

For all textile floorings without foam backing. Cuts from top to bottom

#15641

Accessories:

Spare blades (10 pcs.)

#13454

Recommended by:



Double head stretcher

Developed and manufactured by WOLFF to balance pattern drift and correct seams. Can be adjusted to any carpet by setting the coarse and fine teeth

#15781

Includes:

Double head stretcher, carrying case

Recommended by:

GIRLOON **INFLOOR**
carpet-fashion



Adjustable knee kicker

With coarse and fine teeth. Coarse teeth comes with depth adjustment to adjust to the flooring.

Length adjustment in 5 steps from 50 to 60 cm

#51509

Accessories:

Impact padding

#15797

Fine teeth insert, 3 pcs.

#15798

Rough base plate

#15799



TOOLS FOR LAYING TEXTILE FLOOR COVERINGS

EasyCut

Enables perfect cutting along the wall due to the inclined blade position. The height of the base plate and the cutting depth can be adjusted for different floor covering thickness. This allows for the flooring covering to be cut and not anything underneath.

#10807

Spare blades (hook-break-off blades) 10 pcs.

#10830



Carpet strip cutter C-cut

To accurately cut carpet skirting. Strip width 2 - 7 cm

#47414

Includes:

C-Cut, 10 blades (1 already mounted)

Accessories:

Spare blades, 10 pcs.

#13454



Carpet strip cutter

Extremely hard-wearing and easy to guide! Comes with reinforced blade mount.

To cut material for skirting strips from 45 mm to 100 mm.

#13458

Includes:

Carpet strip cutter, 10 blades

Accessories:

Spare blades, 10 pcs.

#13454



Carpet cutter, green

For textile flooring with foam backing. Cuts from the bottom, with slip-on base.

To double-cut short pile material

#13456

Includes:

Carpet cutter with slip-on base, 10 blades

Accessories:

Spare blades, 10 pcs.

#13457



Carpet cutter, red

For all textile floorings without foam backing. Cuts from top to bottom

#13455

Includes:

Carpet cutter, 10 blades

Accessories:

Spare blades, 10 pcs.

#13454



Circular cutter

For repairing floor coverings. Adjustable from 4 cm to 21 cm diameter

#15624

Includes:

Circular cutter, 4 blades

Accessories:

Spare blades, 6 pcs.

#80578



TOOLS FOR LAYING TEXTILE FLOOR COVERINGS

Seam clamp

To hold difficult seams until the adhesive sets (5 pcs)

#13593



Seam roller, 13 cm wide

Woven or bonded carpet seams are firmly pressed into the adhesive to create a perfect join

#13943



Stair tool with roller

To fix carpets behind the gripper or near stairs

#65853



Stair tool

To fix carpets behind the gripper or near stairs

Stair tool, 7 cm

#13809

Stair tool, 9 cm

#13862



Claw tool

Claw tool

#15802



Carpet shears

Carpet shears for right-handed users, 25 cm

#15654



Universal carpet shears

Universal shears, 25 cm

#15659

Carpet shears, serrated blade, 22 cm

#15652



Napping shears

Napping shears, 14 cm

#15653

Napping shears, 18 cm

#15658



WOOD BEVELLER

Simple renovation of solid wood planks

- Quick retightening of V-grooves
- Guide wheels for accuracy
- Safe and easy to use



DOOR CASE SAW PIRANHA

ALSO AVAILABLE AS A 18V BATTERY POWERED OPTION

See page 79



#67323 - 230V (EU)

Wood Beveller

- machine to reintroduce the bevel between planks after sanding solid wood flooring
- guide wheels for accuracy
- safe and easy to use

Technical specifications:

230 V, 50/60 Hz, 1,500 W, 8,000 rpm, weight 5.2 kg, noise level 91 dB(A), sound power level 107 dB(A), hand-vibration < 2.5 m/s², groove depth 0–5 mm, hard metal grooving disc, diameter 130 mm, thickness 9.0 mm, teeth 6

Includes:

Wood beveller, bevelling disc for profile bevels, adapter for industrial vacuum cleaner, protective goggles, hearing protection, tool kit, dust bag, transport box

Accessories:

Bevelling disc for profile bevels

#63011

#16927 - 230V (EU)

Door case saw Piranha

#20821 - 115V (UK)

#39452 - 115V (US)

With HM saw blade. For exact cutting of doors, door frames and skirting in situ. Can also be used for cutting wood and laminate floors after installation.

- variable height and depth adjustment: height 25 mm, depth 50 mm
- 1.01 kW motor for more power
- HM saw blade for a long service life
- 6,000 rpm

Includes:

Door saw with HM blade, Systainer box

Accessories:

HM saw blade

#17227

USEFUL TOOLS



BLADES | KNIVES | STRAIGHT EDGES | WORK SAFETY EQUIPMENT

KNIVES AND ACCESSORIES

WOLFF-knife

Blade can be swapped without a screw driver. Plastic sheath. Without blades.
Delivered in appealing POS dispenser for orders of 20 pcs. or more

#48221

- with fixing magnets for convenient blade change
- premium quality knife
- specially hardened blade mount



Blades Tried and tested, top quality blades.

Straight blades 0.65mm 10 pcs.

#89530

Straight blade 0.65 mm, 100 pcs., in dispenser

#13419

Hooked blades 0.65 mm 10 pcs.

#89522

Hooked blades, 0.65 mm, 100 pcs., in dispenser

#13421

Super hooked blades 0.65 mm 10 pcs.

#89527

Super hooked blade, 0.65 mm, 100 pcs., in dispenser

#13422

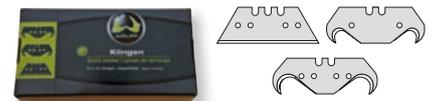

Break-off knife

Delivered in appealing POS dispenser for orders of 20 pcs. or more

#55030

Accessories:

Break-off blades 18 mm 10 pcs.

#89521

Break-off blade 18 mm, 100 pcs., in appealing alloy box.

#13420

Sheath

#62727



Double knife sheath for WOLFF knife #48221

Made of leather, for durability and security.
With spare blade holder

#15591



Universal floor laying knife

Universal floor laying knife

#12299

- aluminium blade for cutting carpets, vinyl flooring, bitumen sheeting, insulation, etc.
- easy blade exchange thanks to improved locking system
- inner blade compartment
- complete with safety case



Blades with titanium coating

Extremely long life and sharpness.
Delivered in convenient alloy box.

Titanium coated straight blades 10 pcs.

#89532

Straight blade with titanium coating, 100 pcs.

#21149

Titanium coated hooked blades 10 pcs.

#89524

Hooked blade with titanium coating, 100 pcs.

#21150

Titanium coated super hooked blades 10 pcs.

#89531

Super hooked blade with titanium coating, 100 pcs.

#21151



Combined hooked/straight blade

Double-sided cutting blades, 100 pcs.

#32713



Half moon blade

Half moon blades 100 pcs.

#32760

Half moon blades 10 pcs.

#89523



Designer cutting knife

Handle, including blade

#13880

Accessories:

Blade no. 22, 10 pcs.

#15617

Handle for spare blade

#15619



SHEARS AND ACCESSORIES

Pica-Dry Marker

Marker for hard to reach places on construction sites. For all surfaces.
With dust and moisture protection.

#84773

Accessories:

Refill green 10 pcs.

#84775

Refill graphit 10 pcs.

#84774



Height scriber

For accurate marking of skirting height

#15555



Skirting board shears

With stop

#15651

Accessories:

Spare pad 1 pcs.

#60736

Mitre-box stop 90 degrees

#33196

Spare blades 1 pcs.

#17471

Bolt with nut and sleeve (Set)

#71213



Mitre-box shears

Double action, with stop, for wood and plastic

#15648

Accessories:

Spare blade 1 pcs.

#15649

Spare pad 1 pcs.

#15650



Mitre-box shears for design floors

Double action, with stop

#55031

Accessories:

Spare blades, 50 pcs.

#56530

Blade holder 1 pcs.

#71910



Steel pins 1,000 pcs., uncoated

1.5 x 25 mm

#60425

1.5 x 30 mm

#60426

1.5 x 35 mm

#60427



Skirting board punching machine

To punch the mitres of rigid PVC skirting with a height of 6 - 10 cm

#15915

Accessories:

Spare blade 1 pcs.

#84659

Spare spring 1 pcs.

#15916



FLOOR COVERING AIDS

Flexible steel straight edge

With anti-slip backing. Rubberised, does not scratch the floor.

Guaranteed straightness from 1.5 to 2.0 mm over 3 metres, width 8 cm.

Flexible steel straight edge 205 cm

#13872

Flexible steel straight edge 405 cm

#13873



Flexible steel straight edge

Made of stainless steel, hardened and finely polished. Width 80 mm, thickness 0.5 mm

Flexible steel straight edge 205 x 8 cm

#48421

Flexible steel straight edge 405 x 8 cm

#48422



Flexible steel straight edge with T stop

Flexible steel straight edge, 80 mm wide, 0.5 mm thick, with bore for transverse stop

Flexible steel straight edge 210 x 8 cm

#48425

Flexible steel straight edge 410 x 8 cm

#48426

Flexible steel straight edge 510 x 8 cm

#48428



Cross stop for steel straight edge (T-piece)

Galvanised stop bar, 40 mm wide

Cross stop steel straight edge (T-piece)

#87903



Cambered stainless steel

Made of strip steel, hardened and finely polished. Cambered on one side, length: 80 cm, thickness 0.5 mm.

Cambered stainless steel

#87904



Head seam straight edge

800 x 75 mm

#15561



FLOOR COVERING AIDS

Door straight edge, stainless

With cambered, hardened and polished, 80 mm wide and 0.5 mm thick, stainless steel blades.

Adjustable from 600 to 1200 mm and wooden handle bar.

Door straight edge 600–1200 mm

#87905



Door straight edge, stainless (short)

For particularly narrow doors. Hardened and polished, 80 mm wide and 5.0 mm thick steel blade.

Adjustable from 460 to 730 mm. With wooden handle strip.

Door straight edge, stainless short 460 - 730 mm

#87907



Stair bevel

To determine lengths and angles quickly and easily

#15563

Accessories:

Spare pushbutton 600 mm

#87908

Spare pushbutton 800 mm

#87909

Spare pushbutton 1000 mm

#87910



Chamfer and mitre templates

Includes a triangle template 30 x 15 cm, 90° and 45° angle as well as a chamfer template 23.4 x 19.0 cm

#74949



Spirit Level

Robust aluminium rectangular with, two openings, length 110 cm

#84185



FLOOR COVERING AIDS

Cartridge gun

- for silicone cartridges and tubular bags (400 ml)
- robust full metal construction, hardened push rod
- automatic readjustment
- with trailing stop
- includes universal nozzle

Cartridge gun

#84247



Rubber mallet

Specially designed to install switchTec products!

Weight 335 g, diameter 40 mm

#47450

Weight 600 g, diameter 50 mm

#15901



Soft-head hammer

For diamond segments

Weight 400 g, diameter 50 mm

#80208



Tapping block

Universal, made of plastic, unbreakable

#15852



Hammer bar

Made of solid galvanised steel. The firing pin is equipped with a shock-absorbing

Nylon protective cover

Hammer bar, 42.5 cm

#15832

Hammer bar, 54.5 cm

#13840



FLOOR COVERING AIDS

Slide hammer tool

- length-adjustable version to work in areas difficult to reach
- easy operation for fast working
- hammer, tapping block and hammer bar in a single tool

Length 41 cm	#13626
Adjustable length, 41 or 64 cm	#13627



Roll transport trolley

For transporting and unrolling flooring rolls with a diameter of up to 80 cm. Two roller transport trolleys are required for 4 to 5 m long rolls, since the load per trolley is limited to 250 kg.

Roll transport trolley	#84918
------------------------	--------



Brooms, horsehair blend

Attached with screws.

Broom 50 cm	#15924
Broom 60 cm	#15925
Coir broom, 60 cm	#15926
Metal handle	#15927



WORK PROTECTION

Knee protector 200 Pro

Very comfortable knee protector with hardwearing and waterproof outer layer and wide support area for maximum stability

#81715

Accessories:

Extra inlays

#81717

Extra elastics

#81718



Knee pads

To be inserted into trousers with knee pad pockets

#51560



Safety Poly knee protectors

Ergonomically shaped knee bed for comfort

Certified in accordance with DIN EN 14404, PPE type 1.

Knee pad Safety Poly

#65398



Knee protectors

Corresponds to current DIN standard. Nylon knee protectors, ultra light.

2 elasticised straps with velcro fastener.

#55037



Leather knee protectors

Inner felt lining for comfort

#15813



Rubber knee protectors

Sturdy and protective shaped knee protector with antislip underside

Molded from durable rubber, adjustable strap

#15810



Medical knee protectors

Lightweight rubber knee pads with Velcro closure.

Developed in cooperation with the trade association and medical practitioners to prevent damage to the health of the knee joints.

#89563

Accessories:

Velcro fastener

#17433



SAFETY AT WORK

Hearing protection

Hearing protection #15315

Protective goggles

Protective goggles #15316

Dust mask

Dust mask #16254

Safety gloves

Safety gloves #15809



Dust Mask Air+

The first disposable dust-mask with a fan - removes humidity and CO2.

- with a micro-fan (4 hour battery life)
- very good fit
- added safety through expiratory-outlet
- foldable and easy to adjust

Air+ FFP2: Preserves 94% of the particles up to a size of 0.6µm (10 pcs.) #83925

Air+ FFP3: Preserves at least 99% of the particles dangerous for the health up to a size of 0.6µm (10 pcs.) #83926

Includes:

Dust Mask Air+, without micro fan

Accessories:

Micro fan for Air+ mask #83927



Air cleaner LR 690

Cleans the ambient air during renovation and demolition. #10057 - 230V (EU)

Dangerous, fine dust is filtered by means of coarse and fine dust filter/H-filter.

Further information can be found on page 49



Dust Door System

Simple solution to keep side-rooms dust free. A zip allows access if needed.

The very stable fabric is ideal for long-term use and is easy to install. #84246



CLEANSPACE

Fan-powered dust mask, for protection against dust and pollutants

CLEANSPACE EX

Fan-powered breathing protection, especially designed for hazardous environments

- For working environments with high dust-exposure
- Easy to clean
- Comfortable to wear and made for long operating times



CleanSpace

- low weight and compact
- intrinsically safe (ICEC- und ATEX-Approvals)
- no hoses, cables or battery-belts
- operating time up to 8 hours
- overpressure Dust Mask with breath-response
- particulate and gas filters available

Technical data:

Visual and audible alarms – 75dB(A) – at ear , Max. Airflow: 220 l/min, Automatic Switch-Off 3 minutes after idle , Weight (Power unit): 500g , AC Adaptor charger: Input range 100 – 240V , Internal battery charging time < 2 hours (to 95%), Output range 13.5V ± 5%

Cleanspace without mask	#79922
Half mask large	#79923
Half mask medium	#79924
Half mask small	#79925

Accessories:

Combination filter A1P3 (organic Gas & steam + particles)	#79931
Combination filter ABE1P3 (organic, inorganic & acid & steam + particles)	#79932
Filter adaptor	#79930
Particle filter (3 pcs.)	#79927
Pre-filter (10 pcs.)	#79928

CleanSpace EX

- especially for hazardous areas
- compatible with CleanSpace full masks

Technical data:

Visual and Audible Alarms – 75dB (A) at ear, Maximum air flow – 220L/min, Automatic Switch-Off 3 minutes after idle, Weight (Power unit): 500g, AC Adaptor charger: Input range 100 – 240V, Internal battery duration – UP to 8 hours, Internal battery charging time < 2 hours (to 95%), Output range 13.5V ± 5%

Cleanspace EX without mask	#84209
Half mask large	#79923
Half mask medium	#79924
Half mask small	#79925
Full face mask	#84239

Accessories:

Combination filter A1P3 (organic Gas & steam + particles)	#79931
Combination filter ABE1P3 (organic, inorganic, acid & steam + particles)	#79932
Filter adaptor	#79930
Particle filter (3 pcs.)	#79927
Pre-filter Clean Space Ex	#84206
Protection cover Clean Space Ex	#84208

EXTENSION CABLES

Cable drum

Cable length 25 meters (3 x 2.5 m²), ABS case, with thermo switch (EU plug)

#80460



Extension cable WOLFF 2.5²

Extension cable, 25.0 m, 2.5² (EU plug)

#41811

Extension cable, 12.5 m, 2.5² (EU plug)

#47382



Extension cable black 1.5²

10 m, 230 V, 1.5² (EU plug)

#36690



Extension cable 400 V

25 m, 400 V, 16 A

#15960



External starting current limiter

Provides the connected machine with low voltage only when turned on.

Ideal to solve problems and save time when working in poorly protected areas.

Starting current limiter with EU plug

#13639

As above, with Swiss plug

#13986



CLEANING AND CARE



CLEANING | CARE

CLEANING MACHINES

Cleanfox

New cleaning machine for basic, intermediate and final cleaning.

- use in battery or current mode
- for indoor and outdoor use

10 Ah battery capacity, 7.5 l pure water tank	#83124
20 Ah battery capacity, 7.5 l pure water tank	#83125

Technical data:

Battery 24 V, operating-time: 1 hour, Cleaning-width 330 mm, Suction-width 420 mm, Ground coverage up to 800 m²/h, weight: ca. 26.5 kg (including battery), Capacity – clean/ dirty water: 7.5 / 8 l, specific pressure step 1/2/3: 36 / 75 / 160 g/m²

Includes:

Cleanfox incl. battery, cylindrical brush medium (blue), battery charger

Accessories:

Cylindrical brush soft (grey)	#83146
Cylindrical brush medium (blue)	#83145
Cylindrical brush hard (black for ceramic and stone floors)	#83147
Tynex brush (green – for safety surfaces)	#83148
Microfiber cloth (green – for all sensitive floors)	#84569
Microfiber cloth (for microfibre brush)	#83929
Battery charger for your car	#83152
Replacement battery 10 Ah	#83150
Replacement battery 20 Ah	#83151
Power device (connection to the mains instead of battery operation)	#83153
Suction-lips	#83933
Suction-lips set para (red)	#83149



Polishing machine Rumba 0.5 kW

Ideal for polishing, cleaning or finishing small areas #13509 - 230V (EU)

- small and lightweight machine for all types of polishing work on hard floors
- also suitable for wet cleaning carpets or hard floors in combination with the cleaning tank

Technical specifications:

230 V/500 W, 188 rpm, 19 kg, working width 330 mm

Includes:

Polishing machine Rumba, without disc holder and cleaning tank

Accessories:

Polishing brush, soft	#13521
Polishing brush, hard	#13522
Disc holder for pads	#13520
Polishing pad	#13523
Cleaning tank	#13502



Monodisc grinding machine Tango 1.0kW

Versatile 1.0 kW machine with a broad range of applications #56366 - 230V (EU)

- grinding screeds or compounds
- sanding wood flooring and cork
- wet cleaning carpets and polishing hard floors

Technical specifications:

230 V, 1.0 kW, 154 rpm, 41 kg, working width 375/400 mm

Includes:

Grinding machine Tango, without suction kit and disc holder



CLEANING ACCESSORIES

Power Cleaner

Highly active cleaner for machines, engines and tools.

#80229



Shampooing brush

With soft bristles to clean carpets

#13506

Perlon brush, hard, not shown

With hard Perlon bristles for rough cleaning of hard flooring (linoleum, PVC, stone, ceramics)

#13506



Corrugated wire brush

For brushing and pre-cleaning of surfaces

#13509

Polishing brush, coir, not shown

For brushing and polishing hard flooring (linoleum, PVC, stone, ceramics)

#13505



Disc for natural stone

For cleaning natural stone floors. Not to be used on the monodisc grinding machine Mambo!

Disc for natural stone

#33209

Scrub brush, Not shown

For maintenance cleaning of hard flooring with coarse or caked soiling

#13508



WOOD FLOORING FRANK



WOOD SANDING MACHINES | ABRASIVES

SPIDER

Sanding has never been so easy!

- Extremely easy to use
- Perfect sanding results
- Quiet in operation



#80113 - 230V (EU)

Sanding machine Spider

#78319 230V (UK)

#80385 230V (US)

- connectible power reserve
- additional weights increase the sanding pressure
- perfect sanding because of the three disc technology
- durable chain drive
- easy to clean
- variable speed control
(50 - 400 rpm, with forced drive 63-504 rpm)
- safety grip
- smooth start
- variable handle adjustment
- quality stainless steel
- big soft tyres (none marking)

Technical Data:

Supply voltage 230 V, power consumption 2,000 W,
Rotation speed 50–400 rpm, with satellite add-on drive 63–504 U/Min,
Total weight 42 kg, sanding width 400 mm

Includes:

Spider,
3 x 83903 ceramic plus Velcro disc 178 mm 10-hole K 50
3 x 62003 Zirconium Velcro disc 178 mm 10-hole K 60
3 x 83905 silicon carbide Velcro disc 178 mm 10-hole K 80

Accessories:

Additional weight	#72225
Dust seal ring	#86015
Disc holder	#79671
Sponge padding (Alu)	#73555
Brush set (structuring of wooden floors)	#83338

COBRA 09

Proven technology in modern design

- Powerful and safe
- 2,500 W Grinding capacity
- Quiet and smooth running



transport trolley
(available as a accessory)

#62228 - 230V (EU)

Sanding machine Cobra 09

#59906 230V (UK)

#52552 230V (US)

- utilises the maximum width of the belt to provide high sanding capacity
- height-adjustable handle
- control panel operation: all switches are easily accessible for more convenient operation
- lighting can be switched on to highlight working area
- bag-in-bag system: disposable inner dust bags
- includes bag for maximum dust reduction by vacuum
- very smooth and silent
- automatic belt tensioning
- quick and convenient belt replacement
- running gear can be adjusted easily
- narrow and compact design
- handle, motor and dust pipe can be disassembled for easy transportation

Technical specifications:

230 V, 2.5 kW, roller width 200 mm, roller speed 2,100 rpm, abrasive belt dimensions 200 x 750 mm, total weight 88 kg, connection for external dust extraction and voltmeter

Includes:

Cobra sanding machine, tool bag, 2 dust bags and 10 plastic inner dust bags, 12 m PUR cable, hearing protection, dust mask, special spare V belt

Accessories:

Sanding roller	#13587
Dust bag	#71730
Disposable inlays, 10 pcs.	#52442
Large pneumatic tyres for a easy transportation of the machine even over long and difficult distances. Safe base to store and fix the machine in a vehicle.	#64310

COBRA CLASSIC

Powerful belt sanding machine with 200 mm working width

- High sanding capacity
- Shoulder free sanding
- Easy transportation



#71845 - 230V (EU) Sanding machine Cobra Classic

- abrasive belt ensures high sanding capacity
- grooved roller for additional sanding effect
- soft raising for shoulder free sanding
- effective dust extraction
- sanding pressure is set with the roller control
- detachable steering rod and motor for easy transportation

Technical specifications:

230 V, 2.5 kW, roller width: 200 mm, limiting roller speed: 2,100 rpm, abrasive belt dimensions: 200 x 750 mm, weight: 83.5 kg

Includes:

Tool bag, 1 x dust bag, PUR cable 12 m, hearing protection, dust mask, abrasive belt kit 2 x grit 36, 2 x grit 60, 1 x grit 100, 2 x Corundum grinding belts grit 36 u. grit 60, 1 x Corundum grinding belts grit 100

Accessories:

Sanding roller	#13587
Dust bag	#71730
Disposable inlays, 10 pcs.	#52442
Transport carriage	#81446

PYTHON CLASSIC

Powerful belt sanding machine with 250 mm working width



#71844 - 230V (EU)

Sanding machine Python Classic

- abrasive belt ensures high sanding capacity
- grooved roller for additional sanding effectiveness
- soft lowering for sanding with no visible overlap
- effective dust extraction
- sanding pressure can be adjusted using the roller control
- detachable steering rod and motor for easy transportation
- belt can be adjusted from the outside for safety

Technical specifications:

230 V, 2.5 kW, roller width 250 mm, roller speed 2,100 rpm, abrasive belt dimensions 250 x 750 mm, weight 90 kg

Includes:

Python sanding machine, abrasive belt set 2 x grit 36, 2 x grit 60, 1 x grit 100, tool bag, dust bag, 12 m cable

Accessories:

Sanding roller	#43879
Dust bag	#71730
Transport carriage	#64310

GECKO STAR 2.0

The newest generation of edge sanding machines

- Robust and smooth sanding
- Ideal position of the handles
- Efficient dust extraction
- Working light

GECKO FLEX

Small and versatile edge sanding machine with high removal rate

- For edges, corners and stairs
- Ideal position of the handle
- Virtually dust-free when connected to the Starvac vacuum (see page 44)



Edge sanding machine Gecko Star 2.0

Technical specifications:

230 V/115 V, 50 Hz, 1800 W, diameter of sanding plate 150/178 mm, 3,000 - 3,800 rpm, weight 9.6 kg, sanding attachment length Ø 150 long 370 mm/ short 130 mm, sanding attachment length Ø 178 long 385 mm/ short 175 mm, adapter for external suction kit 38/35 mm, height adjustment range of the wheels 12 mm

Includes:

Edge sanding machine Gecko Star with sanding attachment, 1 adapter for Starvac, 3 hose holders, 1 dust pipe long, 1 dust pipe short, dust bag, hearing protectors, dust mask, hook-and-loop shim, spare hookandloop disc, 2 hook-and-loop tape

Gecko Star Ø 150 mm, short sanding attachment	#71735 - 230V (EU)
Gecko Star Ø 150 mm, long sanding attachment	#71742 - 230V (EU)
Gecko Star Ø 178 mm, short sanding attachment	#71743 - 230V (EU)
Gecko Star Ø 178 mm, long sanding attachment	#71791 - 230V (EU)

#71782 - 230V (EU) Edge sanding machine Gecko Flex

Technical specifications:

230 V, 50 Hz, 1,500 W, diameter of sanding plate 180 mm, 1400-4200 rpm, weight 4.5 kg, M14 thread, connection for external dust extraction 28 mm

Includes:

GECKO FLEX, Velcro plate, tensioning plate, spare brush, lateral handle, hearing protectors, dust mask hook-and-loop discs grit 40 and grit 80, 3 hose holders, Tools, connection for Starvac

Accessories:

Carrying case	#64135
---------------	--------

ACCESSORIES FOR BELT SANDING MACHINES

Corundum abrasive belts 200 x 750 mm

Grit	packaging unit	
G 12	10 PCS.	#15759
G 16	10 PCS.	#12621
G 24	10 PCS.	#12622
G 30	10 PCS.	#12623
G 36	10 PCS.	#12624
G 40	10 PCS.	#12625
G 50	10 PCS.	#12626
G 60	10 PCS.	#12627
G 80	10 PCS.	#12628
G 100	10 PCS.	#12629
G 120	10 PCS.	#12630



Corundum abrasive belts 250 x 750 mm

Grit	packaging unit	
G 24	10 PCS.	#48546
G 36	10 PCS.	#48542
G 40	10 PCS.	#48660
G 60	10 PCS.	#48543
G 80	10 PCS.	#48548
G 100	10 PCS.	#48544
G 120	10 PCS.	#48549



Zirconia abrasive belts 200 x 750 mm

Grit	packaging unit	
G 24	10 PCS.	#11478
G 36	10 PCS.	#11479
G 40	10 PCS.	#11480
G 60	10 PCS.	#11481
G 80	10 PCS.	#11482
G 100	10 PCS.	#11483
G 120	10 PCS.	#11484



Corundum abrasive belts 200 x 550 mm

Grit	packaging unit	
G 16	10 PCS.	#38176
G 24	10 PCS.	#11485
G 36	10 PCS.	#11486
G 40	10 PCS.	#11487
G 60	10 PCS.	#11488
G 80	10 PCS.	#11489



ACCESSORIES FOR EDGE SANDING MACHINES

Grinding discs 150 mm with hole

Grit	packaging unit	
G 24	25 PCS.	#12640
G 36	25 PCS.	#32690
G 40	25 PCS.	#12642
G 60	25 PCS.	#12643
G 80	25 PCS.	#12644
G 100	25 PCS.	#12645



Grinding discs 178 mm with hole

Grit	packaging unit	
G 24	25 PCS.	#12649
G 36	25 PCS.	#33231
G 40	25 PCS.	#12661
G 60	25 PCS.	#12662
G 80	25 PCS.	#12663
G 100	25 PCS.	#12664



Hook-and-loop discs 150 mm with hole

Grit	packaging unit	
G 16	25 PCS.	#41054
G 24	25 PCS.	#41055
G 36	25 PCS.	#41056
G 40	25 PCS.	#41057
G 60	25 PCS.	#41059
G 80	25 PCS.	#41060
G 100	25 PCS.	#41111
G 120	25 PCS.	#41112



Hook-and-loop discs 178 mm with hole

Grit	packaging unit	
G 16	25 PCS.	#41113
G 24	25 PCS.	#41114
G 36	25 PCS.	#41115
G 40	25 PCS.	#41117
G 60	25 PCS.	#41119
G 80	25 PCS.	#41120
G 100	25 PCS.	#41121
G 120	25 PCS.	#41122



Pajarito®

QUALITY SINCE 1923



SERVICE

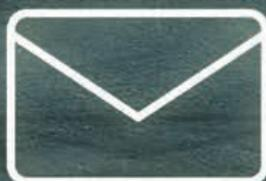
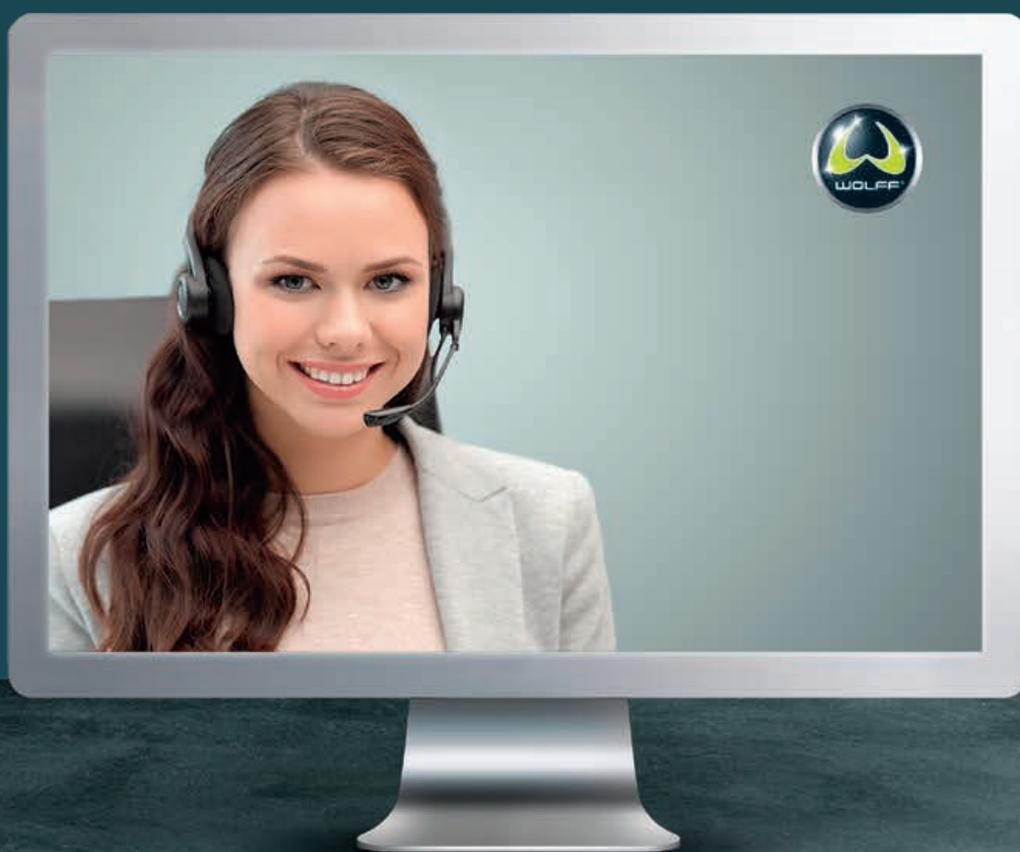

CONTACT ADDRESSES WORLDWIDE

Contact information

Customer service for commercial customers:

Orders /order processing:

Telephone + 49 731 4097-301

Fax + 49 731 4097-230

E-mail info@wolff-tools.com

Technical Customer Service:

Telephone + 49 7062 91556 - 28, -43, -54, -59

Fax + 49 7062 91556-55

E-mail tk-s-wolff@wolff-tools.com

Application Technology

Frank Wehrmann

Mobile +49 160 883 6031

E-mail frank.wehrmann@wolff-tools.com

Karl-Heinz Würth

Mobile +49 160 364 2058

E-Mail karl-heinz.wuerth@wolff-tools.com

Availability

Montay - Friday 7:30 - 16:15



Australia

Uzin Utz Soutz Pacific Ltd.

PO Box 426 - Whangaparaoa 0943

Telephone +64 21 933780

Telefax +64 9 4240366

E-mail uzin.sp@uzin-utz.com



Azerbaijan

Uzin Utz AG

Dieselstrasse 3

Germany, 89079 Ulm

Telephone +49 731 4097 205

Telefax +49 731 4097 107

E-mail boris.schulmann@uzin-utz.com

E-mail biuro@uzin-utz.com



Republik Belarus

Representative Office Uzin Utz AG

220035 Minsk

Cimirazieva Strasse 67, Office 932

Postfach 121

Telephone +375 (17) 235 00 50

Telefax +375 (17) 235 00 50

Mobil +375 (29) 655 56 26

E-mail Ivan.rak@uzin-utz.com



Belgium

Uzin Utz Belgie n.v.

Poortakkerstraat 41 a

B-9051 Gent

Telephone +32 9 2225848

Telefax +32 9 222 3380

E-mail info@unipro.be



China

Uzin Utz Construction

Materials (Shanghai) Co. Ltd.

N° 3968 Huqingping Highway

Zhaoxiang - District Qingpu

Shanghai 201703

Telephone +86 21 5975 7890

Telefax +86 21 5975 8695

E-mail info@uzin.com.cn



Croatia

Uzin Utz Hrvatska d.o.o.

Trgovačka 6

CMP, Savica-Šanci

HR-10000-Zagreb

Telephone +385 1 2498214

Telefax +385 1 2498215

E-mail sales.hr@uzin-utz.com



Cyprus

IDS – Interior Design Services

Total Solution Contract

197 Old Nicosia

Limassol Road P.O Box 11107

Nicosia

Telephone +357 22461133

Telefax +357 22610020

E-mail idsids@cytanet.com.cy



Czech Republic

Uzin Utz Česká Republika s.r.o.

Českomoravská 12a

CZ-19000 Praha 9

Telephone +420 2 8308 3314

E-mail cz@uzin-utz.com



Denmark

Uzin Utz Denmark

Kongelundsvej 294

2770 Kastrup

Telephone +45 2584 8003

E-mail dk@uzin-utz.com



Estonia

Gitana OÜ

Artellistr. 19

10621 Tallinn

Telephone +372 52 97 343

E-mail info@gitana.ee

Internet www.gitana.ee



Finland

WOLFF GmbH Co. KG

Thilo Wolff

Ungerhalde 1

D-74360 Ilsfeld

Telephone +49 7062 91556 0

Mobil +49 151 2926296 1

E-mail thilo.wolff@wolff-tools.com

Internet www.wolff-tools.de



France

Uzin Utz France SAS

6 avenue du Professeur André Lemierre

F-75980 Paris Cedex 20

Telephone +33 (0)1 41 63 27 20

Telefax +33 (0)1 41 63 27 21

E-mail uzin.fr@uzin-utz.com



Germany

Wolff GmbH & Co. KG

Ungerhalde 1

D-74360 Ilsfeld

Telephone +49 7062 91556 0

Telefax + 49 7062 91556 10

E-mail info@wolff-tools.com

Internet www.wolff-tools.de



Greece

Uzin Hellas

Polychimiki G. Matziaris S.A.

14 km National Road

Thessaloniki-Veria

GR-57011 N. Anchialos

Telephone + 30 2310 7229 912

Telefax + 30 2310 7225 71

E-mail uzin@otenet.gr

 **Hungary**
Uzin Utz
Magyarország Kft.
 Bányató u. 13
 H-1108 Budapest
 Telephone + 36 1 431 9422
 Telefax + 36 1 431 9423
 E-mail info-hungary@uzin-utz.com

 **Iceland**
Gólfefni ehf.
Magyarország Kft.
 Skútuvogi 6
 104 Reykjavík
 Telephone + 354 568 6755
 Telefax + 354 568 1277
 E-mail alfaborg@alfaborg.is

 **Indonesia**
PT Uzin Utz
 Plaza Pasifik B2 No. 32
 Kelapa Gading
 ID - Jakarta 14240
 Telephone + 62 21 4587 6116
 Telefax + 62 21 4587 6115
 E-mail sugi_wei@yahoo.com

 **Latvia**
SIA „Gitana tehniskais nodrošinājums“
 Zemnieku str. 60
 LV-3401 Liepāja,
 Telephone + 371 634 813 05
 E-mail info@gitana.lv
 URL: www.gitana.lv

 **Lithuania**
UAB Gitana
 Biciuliu str. 32
 Budriku village
 LT-96320 Klaipėdos r.
 Telephone + 370 46 410 881
 Telefax + 370 46 310 485
 E-mail info@gitana.lt
 URL: www.gitana.lt

 **Lithuania**
UAB Gitana Service
 Biciuliu str. 30
 Budriku village
 LT-96320 Klaipėdos r.
 Lithuania
 Telephone +370 700 55019
 E-mail servisas@gitana.lt
 URL: www.gitana.lt

 **Malta**
de Valier Co. Ltd.
 Fairline Centre - St.Marta Street
 Victoria Gozo - VCT 2552
 Telephone + 356 21 556694
 Telefax + 356 21 554175
 E-mail info@devalier.com.mt

 **Netherlands**
Uzin Utz Nederland bv
 Bouwstraat 18
 7483 PA HAAKSBERGEN
 Telephone + 31 (0) 53 5737373
 Telefax + 31 (0) 53 5737333
 E-mail info@uzin.nl

 **New Zealand**
Uzin Utz South Pacific Ltd.
 PO Box 426 - Whangaparaoa 0943
 Telephone + 64 21 933780
 Telefax + 64 9 4240366
 E-mail info@ufloor-systems.net

 **Norway**
Uzin Utz Group Norge AS
 Elveveien 34 – bygg 4
 N-3262 Larvik
 Telephone + 47 35 50 64 00
 E-Mail info@uzin-utz.com

 **Poland**
Uzin Polska Sp.z o.o
 ul. Jaworzy ska 287
 PL-59-220 Legnica
 Telephone + 48 76 723 9150
 Telefax + 48 76 723 9151
 E-mail biuro@uzin-utz.com

 **Russia**
Uzin Utz AG
 Dieselstrasse 3
 Germany, 89079 Ulm
 Telephone + 49 731 4097 205
 Telefax + 49 731 4097 107
 E-mail boris-schulmann@uzin-utz.com
 E-mail biuro@uzin-utz.com

 **Serbia**
Uzin Utz Srbija d.o.o.
 Bulevar Peka Dapčevića 43
 11041 Beograd
 Telephone + 381 11 3989 044
 Telefax + 381 11 3989 088
 E-mail sales.rs@uzin-utz.com

 **Slovakia**
HA-UZ market s.r.o.
 Štrkova ulička 94
 SK-01001 Zilina
 Telephone + 421 41565 1794
 Telefax + 421 41500 6014
 E-mail ha-uz@za.psg.sk

 **Slovenija**
Uzin Utz Slovenija d.o.o.
 Kajakaška c. 30
 SLO-1211 Ljubljana
 Telephone + 386 1 511 0200
 Telefax + 386 1 511 6290
 E-mail sales.si@uzin-utz.com

 **Spain**
 Frank Keerl, S.A.
 C/Amadeo Torner 109
 08902 Hospitalet de Llobregat
 Telephone +34 93 422 81 00
 Telefax + 34 93 432 1098
 correo electronico: info@frankkeerl.com
 www.frankkeerl.com

 **Sweden**
Flex Scandinavia AB
 Service center
 www.flexscandinavia.se
 Email: service@flexscandinavia.se
 Tel: +46 54 52 20 08

Visit address:
 Sågverksgatan 28
 652 21 Karlstad
 Post address:
 Box 5040
 650 05 Karlstad

 **Switzerland**
DS-Derendinger AG
 Freiburgerstraße 830 a
 CH-3174 Thörishaus
 Telephone + 41 31 888 12-00
 Telefax + 41 31 888 12-01
 E-mail info@ds-derendinger.ch

 **Turkey**
DENLAKS Adhesives
 Cihangir Mash, Güvercin Cad. No: 11
 Haramidere
 Avcılar 34310 Istanbul
 Telephone + 90 212 4221100
 Telefax + 90 212 4221099

 **South Africa**
Contract Flooring Distribution (Pty) Ltd.
 22 Dublin Road
 Brabley View Ext 6
 Johannesburg 2090
 Telephone + 27 11 882 1000
 Telefax + 27 11 882 5403
 E-mail info@cdflooring.co.za

 **United Kingdom**
Uzin Utz UK Ltd.
 Unit 2, Mitchell Court
 Central Park, Rugby
 Warwickshire, CV23 0UY
 Telephone + 44 1788 530 080
 Telefax + 44 1788 536 508
 E-Mail uk@uzin-utz.com

 **Ukraine**
Uzin Representative Office
 Dr. Yuri Rudchenko
 DIC, 43, Borodinska St.
 49029 Dnepropetrovsk, Ukraine
 Telephone + 38 056 744 8843
 Telefax + 38 056 44 8843
 E-Mail uzinua@i.ua

 **USA & Canada**
Uzin Utz North America
 Aurora, CO 80011 USA
 Telephone +866.505.4810
 E-Mail wolfftools.us@uzin-utz.com
 URL wolfftools.com

All other countries:
 Wolff GmbH & Co. KG
 Thilo Wolff
 Ungerhalde 1
 D-74360 Ilsfeld
 Telephone + 49 7062 91556 0
 Telefax + 49 7062 91556 10
 E-Mail info@wolff-tools.com
 Internet www.wolff-tools.de

NUMERIC INDEX

1

10057	Air cleaner LR 690 230V (EU)	49, 115	12642	Grinding discs 150 mm with hole G40 25 PCS.	128	13385	Adhesive Notch, TKB B1, 28 cm 10 pcs.	62
10068	Carpet clamp with wooden handle	24	12643	Grinding discs 150 mm with hole G60 25 PCS.	128	13386	Adhesive Notch, TKB B2, 28 cm 10 pcs.	62
10287	Piranha 18V only	79	12644	Grinding discs 150 mm with hole G80 25 PCS.	128	13387	Adhesive Notch, TKB B3, 28 cm 10 pcs.	62
10289	Piranha 18V set EU	79	12645	Grinding discs 150 mm with hole G100 25 PCS.	128	13388	Adhesive Notch, TKB A2, 28 cm 10 pcs.	62
10290	Piranha 18V set UK	79	12649	Grinding discs 178 mm with hole G24 25 PCS.	128	13389	Adhesive Notch, TKB A3, 28 cm 10 pcs.	62
10294	Piranha 18V set USA	79	12661	Grinding discs 178 mm with hole G40 25 PCS.	128	13390	Adhesive Notch, TKB A4, 28 cm 10 pcs.	62
10318	Strip Cutter LS65 18V only	77	12662	Grinding discs 178 mm with hole G60 25 PCS.	128	13391	Adhesive Notch, TKB A5, 28 cm 10 pcs.	62
10319	Strip Cutter LS65 18V set EU	77	12663	Grinding discs 178 mm with hole G80 25 PCS.	128	13396	Adhesive Notch, TKB R2, 56 cm 10 pcs.	58, 62
10322	Strip Cutter LS35 18V set USA	77	12664	Grinding discs 178 mm with hole G100 25 PCS.	128	13397	Adhesive Notch, TKB R1, 56 cm 10 pcs.	58, 62
10327	Junio-Stripper 18V only	75	12665	Abrasive gauze Ø 406 mm G60	30	13399	Adhesive Notch, TKB B11, 28 cm 10 pcs.	62
10328	Junio-Stripper 18V set EU	75	12666	Abrasive gauze Ø 406 mm G80	30	13400	Adhesive Notch, TKB R1, 21 cm 10 pcs.	62
10329	Junio-Stripper 18V set UK	75	12667	Abrasive gauze Ø 406 mm G100	30	13401	Adhesive Notch, TKB R2, 21 cm 10 pcs.	62
10334	Junio-Stripper 18V set USA	75	12668	Abrasive gauze Ø 406 mm G120	30	13402	Adhesive Notch, TKB R1, 28 cm 10 pcs.	62
10339	Strip Cutter LS35 18V only	77	12669	Abrasive gauze Ø 406 mm G150	30	13403	Adhesive Notch, TKB R2, 28 cm 10 pcs.	62
10344	Strip Cutter LS35 18V set EU	77	12676	Cleaning pads Ø 410/10 mm beige 10 PCS.	32	13404	Adhesive Notch, TKB S2, 21 cm 10 pcs.	62
10346	Strip Cutter LS65 18V set UK	77	12677	Cleaning pads Ø 410/10 mm green 10 PCS.	32	13409	Adhesive Notch, TKB S3, 21 cm 10 pcs.	62
10347	Strip Cutter LS65 18V set USA	77	12678	Cleaning pads Ø 410/10 mm black 10 PCS.	32	13410	Adhesive Notch, TKB S2, 28 cm 10 pcs.	62
10415	Cordless Mixer Power X 18V only	76	12679	Cleaning pads Ø 410/10 mm white 10 PCS.	32	13413	Adhesive Notch, TKB S3, 28 cm 10 pcs.	62
10440	Cordless Mixer Power X 18V set EU	76	12680	Cleaning pads Ø 410/20 mm beige 5 PCS.	32	13419	Straight blades (100 pcs.)	24, 82, 83, 108
10442	Cordless Mixer Power X 18V set UK	76	12691	Cleaning pads Ø 410/20 mm green 5 PCS.	32	13420	Break-off blade 18 mm, 100 pcs.	108
10443	Cordless Mixer Power X 18V set USA	76	12692	Cleaning pads Ø 410/20 mm black 5 PCS.	32	13421	Hooked blades, 0.65 mm, 100 pcs.	24, 82, 85, 108
10509	Air hose connection adapter 205 mm diameter	49	12693	Cleaning pads Ø 410/20 mm white 5 PCS.	32	13422	Super hooked blade, 0.65 mm, 100 pcs.	82, 108
10511	Cover plate for dust formation during mixing	49	13299	Disc holder with sponge padding, Ø 375 mm	30	13424	Joint groover with guiding pin	95
10513	Compact air hose, 125 mm Ø / 6 m length, black	49	13300	Disc holder for pads Ø 400 mm	32	13426	Groover	95
10514	Exhaust air hose transparent 125 mm Ø x 0,15 mm, 88 meters	49	13305	Grooving Machine Fräsmaster 230V (EU)	92	13427	Spare blade for Groover	86, 95
10515	Pre-filter mats G3, 340 x 405 mm (10 pcs.)	49	13308	Speed welding nozzle	99, 100	13429	Spare blades for Linocut, 10 pcs.	81
10516	Coarse filter G4, 1100 m ³ < 45 Pa	49	13314	T-Rex 230V (EU)	48	13430	Standard base 2 mm guide	81
10519	HHEPA H14 Filter, 620 m ³ < 330 Pa	49	13327	Disc holder with sponge padding, Ø 400 mm	30	13431	Needle punch base 4 mm guide	81
10587	Compact air hose, 205 mm Ø / 7,5 m length, black	49	13328	Disc holder with spare sponge padding, Ø 400 mm	30	13432	Carpet base 8 mm guide	81
10807	EASYCUT	104	13329	Abrasive paper discs, double-sided, Ø 400 mm G24	30	13445	Hose clamp, 40 – 60 mm	48
10830	Spare blades (hook-break-off blades) PU 10 pcs.	104	13330	Abrasive paper discs, double-sided, Ø 400 mm G40	30	13449	Base plate for removing factory-cut edges	81
10831	PCD Viper	41	13335	Suction wand 50 mm T-Rex	48	13450	Weld seam slide	101
10832	PCD Viper XT	41	13336	Roller nozzle T-Rex	48	13451	Quarter moon knife	101
10930	Replacement battery 18V 5Ah (1 piece)	75, 76, 77, 78, 79	13337	Suction hose, 50 mm, length 5 m	46, 47, 48	13452	Quarter moon knife, angled	101
10939	Charger 230V EU	75, 76, 77, 78, 79	13338	Hose connection 50 mm	46, 47, 48	13453	Quarter moon knife, bent	101
11478	Zirconia abrasive belts 200 x 750 mm G24 10 PCS.	127	13339	TS 40/T-Rex 50 mm end fitting	48	13454	Spare blades for Mittag cutter (10 pcs.)	103, 104
11479	Zirconia abrasive belts 200 x 750 mm G36 10 PCS.	127	13340	T-Rex 50 mm connecting piece	48	13455	Carpet cutter, red	104
11480	Zirconia abrasive belts 200 x 750 mm G40 10 PCS.	127	13342	Carpet clamp	24	13456	Carpet cutter, green	104
11481	Zirconia abrasive belts 200 x 750 mm G60 10 PCS.	127	13344	Spare blade 210x60x0,7mm 10 PCS.	21, 22	13457	Spare blades for Carpet cutter, green, 10 pcs.	104
11482	Zirconia abrasive belts 200 x 750 mm G80 10 PCS.	127	13345	Spare blade 210x60x1,0mm 10 PCS.	21, 22	13458	Carpet strip cutter	104
11483	Zirconia abrasive belts 200 x 750 mm G100 10 PCS.	127	13346	Spare blade 210x60x1,5mm 10 PCS.	21, 22	13459	HM milling blade 130 X 20 X 3.8 elliptical, Z12	92, 93
11484	Zirconia abrasive belts 200 x 750 mm G120 10 PCS.	127	13349	Metal carrying case	21	13460	Diamond milling blade elliptical 130 x 3.8, Z4	92, 93
11485	Corundum abrasive belts 200 x 550 mm G24 10 PCS.	127	13350	Strip cutter, 0 - 8 cm	85	13461	Combi grooving disc, 5 mm	92, 93
11486	Corundum abrasive belts 200 x 550 mm G36 10 PCS.	127	13351	Strip cutter, 3 - 20 cm	85	13465	Single nozzle, 5mm	100
11487	Corundum abrasive belts 200 x 550 mm G40 10 PCS.	127	13352	Strip cutter, 6 - 30 cm	85	13466	Speed welding nozzle for polyolefin Ø 4 mm	100
11488	Corundum abrasive belts 200 x 550 mm G60 10 PCS.	127	13353	Spare blades for Strip cutter, 5 pairs	85	13467	Mipolam nozzle	100
11489	Corundum abrasive belts 200 x 550 mm G80 10 PCS.	127	13354	Conversion kit, to use hooked blade	85	13468	Gooseneck nozzle	100
11770	Charger 115V USA	75, 76, 77, 78, 79	13355	Seam scriber	91	13469	Correction nozzle, 4 mm	100
11772	Charger 230V UK	75, 76, 77, 78, 79	13356	Scriber needles, 20 pcs.	91	13470	Radiator nozzle	100
12299	Universal floor laying knife	108	13357	Combi scriber	91	13471	Speed welding nozzle	100
12621	Corundum abrasive belts 200 x 750 mm G16 10 PCS.	127	13358	Spare blades, 5 pcs.	86, 91	13472	Broad nozzle 20 mm, angled	100
12622	Corundum abrasive belts 200 x 750 mm G24 10 PCS.	127	13367	Adhesive Notch, TKB A1, 21 cm 10 pcs.	62	13473	Broad nozzle 40 mm	100
12623	Corundum abrasive belts 200 x 750 mm G30 10 PCS.	127	13370	Adhesive Notch, TKB B1, 21 cm 10 pcs.	62	13475	Heating element, 3.3 kW	99
12624	Corundum abrasive belts 200 x 750 mm G36 10 PCS.	127	13371	Adhesive Notch, TKB B2, 21 cm 10 pcs.	62	13476	Round nozzle for Leister Electron ST	99
12625	Corundum abrasive belts 200 x 750 mm G40 10 PCS.	127	13372	Adhesive Notch, TKB B3, 21 cm 10 pcs.	62	13480	Heating element, 3.0 kW	96
12626	Corundum abrasive belts 200 x 750 mm G50 10 PCS.	127	13373	Adhesive Notch, TKB A2, 21 cm 10 pcs.	62	13485	Seam trimmer	95
12627	Corundum abrasive belts 200 x 750 mm G60 10 PCS.	127	13374	Adhesive Notch, TKB A3, 21 cm 10 pcs.	62	13486	CCM device classic	71
12628	Corundum abrasive belts 200 x 750 mm G80 10 PCS.	127	13375	Adhesive Notch, TKB A4, 21 cm 10 pcs.	62	13490	Stone, grit 20	33
12629	Corundum abrasive belts 200 x 750 mm G100 10 PCS.	127	13376	Adhesive Notch, TKB A5, 21 cm 10 pcs.	62	13491	Diamond grindstone	101
12630	Corundum abrasive belts 200 x 750 mm G120 10 PCS.	127	13378	Interchangeable spatula, 21 cm	60	13493	Grinding stone, 20 x 10 x 3,5, with Handle	54
12640	Grinding discs 150 mm with hole G24 25 PCS.	128	13380	Adhesive Notch, TKB B11, 21 cm 10 pcs.	62	13500	Disc holder with Spare sponge padding, Ø 375 mm	30
			13381	Interchangeable spatula, 28 cm	60	13501	Disc holder with felt, Ø 375 mm	30
			13382	Adhesive Notch, TKB A1, 28 cm 10 pcs.	62	13502	Reinigungstank	119

NUMERIC INDEX

13503	Suction kit complete 230V (EU)	28	13763	Nylon roller	59	15353	Brush ring	28
13504	Paper filter bags 40 cm	28	13803	Subfloor strength tester	70	15532	Special blade, Heavy duty, angled, 350 mm	13
13505	Polishing brush, coir	32, 120	13809	Stair tool, 7 cm	105	15551	Roller handle	59
13506	Shampooing brush	32, 120	13813	Round blade for Seam trimmer, 6 mm	95	15552	Super fine foam roller	59
13507	Perlon brush, hard	32, 120	13840	Hammer bar, 54.5 cm	112	15555	Height scriber	109
13508	Scrub brush	32, 120	13841	Adhesive spatula, B1, 25 cm	60	15561	Head seam straight edge	110
13509	Polishing machine Rumba 0.5 kW 230V (EU)	119	13842	Groover for rubber floors (u-shape)	95	15563	Stair bevel	111
13510	HM grinding disc, double-sided Ø 375 mm G16	30	13843	Spare blades U-shape, 10 pcs.	95	15566	Adhesive spatula B2, 18 cm	60
13515	HM grinding disc, double-sided Ø 400 mm G16	30	13862	Stair tool, 9 cm	105	15567	Adhesive spatula B3, 18 cm	60
13517	HM grinding disc, double-sided Ø 375 mm G24	30	13868	Round blade for Seam trimmer, 12 mm	95	15568	Adhesive spatula, w/o profile 18 cm	60
13518	HM grinding disc, double-sided Ø 400 mm G24	30	13870	Flat blade for Seam trimmer	95	15569	Adhesive spatula A1, 25 cm	60
13520	Disc holder for pads	119	13872	Flexible steel straight edge 205 cm	110	15570	Adhesive spatula B2, 25 cm	60
13521	Polishing brush, soft	119	13873	Flexible steel straight edge 405 cm	110	15571	Adhesive spatula B3, 25 cm	60
13522	Polishing brush, hard	119	13876	Adhesive spatula A2, 18 cm	60	15572	Adhesive spatula, w/o profile, 25 cm	60
13523	Polishing pad, Ø 325 mm	119	13877	Adhesive spatula B1, 18 cm	60	15591	Double knife sheath	108
13526	Disc holder with felt Ø 375 mm	30	13878	Corrugated link, 1,000 pcs.	43, 63	15605	Linoleum edge cutter	86
13527	Abrasive paper discs, double-sided, Ø 380 mm G24	30	13879	Spike roller 25 cm / 11 mm	58	15610	Welding rod roller 25 mm	95, 100
13528	Abrasive paper discs, double-sided, Ø 380 mm G40	30	13880	Designer cutting knife	108	15611	Welding rod roller 15 mm	95, 100
13529	Abrasive paper discs, double-sided, Ø 380 mm G60	30	13886	Adhesive spatula A2, 25 cm	60	15617	Blade no. 22, 10 pcs.	108
13530	Abrasive paper discs, double-sided, Ø 380 mm G80	30	13922	Supporting blocks for PressoMess, 100 pcs.	71	15619	Handle for spare blade	108
13532	Abrasive paper discs, double-sided, Ø 380 mm G100	30	13923	Test blocks for PressoMess, 100 pcs.	71	15620	Stair scriber	91
13533	Abrasive paper discs, double-sided, Ø 380 mm G120	30	13926	Mixed adhesive for PressoMess	71	15621	FasTrimmer	91
13534	Abrasive paper discs, double-sided, Ø 400 mm G60	30	13932	Corrugated link, 1,000 pcs.	43, 63	15622	Base for chamfering the floor backing	91
13535	Abrasive paper discs, double-sided, Ø 400 mm G80	30	13934	Floor scraper	24	15623	FasTrimmer for chamfering floor backings	91
13536	Abrasive paper discs, double-sided, Ø 400 mm G100	30	13943	Seam roller, 13 cm wide	105	15624	Circular cutter, 4 - 21 cm	104
13537	Abrasive paper discs, double-sided, Ø 400 mm G120	30	13947	Web for Strip cutter, 5 pcs.	85	15625	Spare blades for Circular cutter, 6 pcs.	86
13539	Corrugated wire brush	32, 120	13978	Spare Blades Turbo 350x60x1,0 mm 10 pcs.	16, 17	15626	Circular cutter	86
13540	Sanding disc with 6 stones grit 20	33	13979	Spare Blades Turbo 350x60x1,5 mm 10 pcs.	16, 17	15628	Joint groover for circular cutter	86
13549	Abrasive gauze, Ø 406 mm G180	30	13980	Spare Blades Turbo 200x60x1,5 mm 10 pcs.	16	15629	Extension rails up to 4.86 m radius	86
13550	Milling module with HM plate	33	13981	Spare Blades Turbo 150x60x1,5 mm 10 pcs.	16	15631	Adapter for corner and wall radius	86
13566	HM Plate (1pc.)	33	13982	Spare Blades Turbo 350x120x1,5 mm	13, 16, 17	15641	Mittag cutter	103
13569	Hard metal (HM) milling plate disc	33	13983	Special 350 mm U-shape blade, Top cutting edge	16	15648	Mitre-box shears	109
13587	Sanding roller Cobra 09/Cobra Classic	123, 124	13986	External starting current limiter (with Swiss plug)	117	15649	Spare blade for Mitre-box shears	109
13593	Seam clamp 5 pcs.	105	14001	Spare blade for Floor scraper	24	15650	Spare pad for Mitre-box shears	109
13594	Copper band, Roll 50 m (width: 10 mm)	63	14019	Ball set, 4 pcs.	71	15651	Skirting board shears with stop	109
13595	Copper band, Roll 200 m (width: 10 mm)	63	14020	Test phials, 10 pcs.	71	15652	Carpet shears, serrated blade, 22 cm	105
13604	Stirrer Typ MK 120 mm	52	14021	Spike roller 50 cm / 21 mm	58	15653	Napping shears, 14 cm	105
13605	Stirrer, type KE 90S	52	14023	Multi grinding plate	31	15654	Carpet shears for right-handed users, 25 cm	105
13606	Stirrer, type KE 120S	52	14038	Hose set with T-piece	28	15658	Napping shears, 18 cm	105
13611	Stirrer Typ MK 160 mm	52, 53	14039	Dust ring	28	15659	Universal shears, 25 cm	105
13617	Spare blades for Hand scraper, 100 pcs. in box	24, 108	14043	Spring washer	30	15661	Electric strip cutter LS35 230V (EU)	85
13619	Rubbing hammer	90	14044	Bolt with left-handed thread	30	15662	Strip Cutter LS35 18V set UK	77
13626	Slide hammer tool, 41 cm	113	14248	Grinding disc with diamond grinding heads	33	15711	Grooving Machine Fräsmaster 115V (UK)	92
13627	Slide hammer tool, adjustable, 41/64 cm	113	14249	Diamond grinding head, fan-type helical design	33	15714	Diamond grindstone	101
13628	Measuring wedge	70	14254	Grinding plate with hard metal ring G16	31	15718	HM grinding stone, G24	54
13636	Spike roller 50 cm / 31 mm	58	14255	Grinding plate with hard metal ring G24	31	15735	Brush cup plate	31
13637	Spike rollers 25 cm / 31 mm	58	14256	Hard metal ring, grit 16	31	15736	Brush cup set, 6 pcs.	31
13638	Spike rollers 75 cm / 31 mm	58	14257	Hard metal ring, grit 24	31	15737	Mounting kit for brush cup set	31
13639	Starting current limiter	42, 117	14261	Fine dust filter for T-Rex	48	15738	Flat steel brush disc	31
13641	Floor milling machine CT 200 230V (EU)	42	14262	T-Rex suction nozzle, round	48	15739	Spare pad for Disc holder Ø 400 mm	32
13642	Milling drum CT 200 with milling blades	42	14263	T-Rex 70 mm add-on nozzle	48	15759	Corundum abrasive belts 200 x 750 mm G12 10pcs.127	
13643	Milling blade set for CT 200, 76 pcs.	42	14264	Add-on nozzle brush set	48	15781	Double head stretcher	103
13644	Intermediate disc set for milling drum CT 200, 76 pcs.	42	14265	Add-on nozzle rubber lip	48	15797	Impact padding for adjustable knee kicker	103
13645	Milling drum CT 200 (not shown) without blades	42	14268	70 mm diameter connecting piece (T40 & T-Rex)	48	15798	Fine teeth insert, 3 pcs. for adjustable knee kicker	103
13646	Shafts for milling drum CT 200, set of 4 pcs.	42	14269	Hose clamp, 60 – 80 mm	48	15799	Rough base plate for adjustable knee kicker	103
13648	Milling drum CT 200 complete with peeling blades	42	14270	Spike roller 75 cm / 11 mm	58	15802	Claw tool	105
13649	Peeling blade set for CT 200, 40 pcs., 10 mm	42	14271	Spike roller 75 cm / 21 mm	58	15807	Hole cutter - diameter 8 – 20 mm	86
13650	Intermediate disc set for peeling blade drum CT 200, 72 pcs.	42	14272	Spike roller 25 cm / 21 mm	58	15809	Safety gloves	115
13658	Pin leveller	57, 58	14273	70 mm end fitting	48	15810	Rubber knee protectors	114
13659	Steel blade for Pin leveller	58	14937	Impact belt Turbo	13	15813	Leather knee protectors	114
13660	Spare pins, 2 pcs.	58	14938	Drive belt Turbo	13	15829	Pouring spouts (10 St.)	53
13662	Carbide phials 100 pcs.	71	14959	Allen key SW 8 for Disc holder	30	15832	Hammer bar, 42.5 cm	112
13761	Adhesive spatula, A1, 18 cm	60	15315	Hearing protection	115	15834	Pressure roller for floor coverings	90
13762	Spike roller 50 cm / 11 mm	58	15316	Protective goggles	115	15852	Tapping block	112

NUMERIC INDEX

51270	Slider for Mozart trimming knife, 0.70 mm	101	61804	Monodisc grinding machine Mambo Evo 230V (EU)	26	7		
51505	Hand scraper WOLFF	24	61933	Wet and dry vacuum cleaner filter for STARVAC MI55	44	70754	Perforated pads, G100 Ø 150 mm	32
51509	Adjustable knee kicker	103	62162	Aluminium floor nozzle, 370 mm for STARVAC MI55	44	71053	Universal hygrometer V1-D4 Professional	65, 68
51546	Adhesive profile, TKB R3, 56 cm 10 pcs.	58, 62	62183	Mozart Speed Trimmer	101	71054	Moisture meter GM-200	67
51549	Nail shoes	63	62227	Chassis for BiTurbo, Turbo and Extro Strippers 11, 13, 14	123	71055	Thermohygrometer LVT 15 Professional	67, 69
51560	Knee pads	114	62228	Sanding machine Cobra 09 230V (EU)	123	71056	Submersible probe TF-01	67, 69
51771	Sample collection	60	62551	Monodisc grinding machine Mambo Evo 115V (UK)	26	71057	Surface probe OF-02	67, 69
51840	Basic grinding disc for diamond segments	33	62562	Membrane filter for STARVAC MI55	44	71213	Bolt with nut and sleeve (Set)	109
52298	Rake to apply smoothing compounds	57, 58	62694	Glide with removable felt coat and handle	90	71730	Dust bag Cobra 09/Classic/Python Cl	123, 124, 125
52442	Disposable inlays, Cobra 09 , 10 pcs.	123, 124	62697	Starvac disposal bags (10 pcs.) for STARVAC MI55	44	71735	Gecko Star Ø 150 mm, short sanding attachment	126
52552	Sanding machine Cobra 09 230V (US)	123	62727	Sheath for Break-off knife	108	71742	Gecko Star Ø 150 mm, long sanding attachment	126
53415	Undercarriage protection for Turbo-Stripper	13	63011	Bevelling disc for profile bevels	106	71743	Gecko Star Ø 178 mm, short sanding attachment	126
54874	Copper band, Roll 2 x 25 m, Self-adhesive roll (10 mm)	63	63047	Monodisc grinding machine Samba 1.700 W / 115V (US)	27	71782	Edge sanding machine Gecko Flex 230V (EU)	126
55030	Break-off knife	108	63752	Deflector for new Turbo version 2	13	71791	Gecko Star Ø 178 mm, long sanding attachment	126
55031	Mitre-box shears for design floors	109	63753	Blade holder for parquet deflector for Turbo2	13	71844	Sanding machine Python Classic 230V (EU)	125
55037	Knee protectors with velcro fastener	114	63754	Wood flooring stripper set Turbo2	13	71845	Sanding machine Cobra Classic 230V (EU)	124
56026	Brush set roller nozzle for T-Rex	48	63998	Greencut	82	71910	Blade holder for Mitre-box shears for design floors	109
56092	Grooving machine Fräsjunior 230V (EU)	93	64135	Carrying case for Gecko Flex	126	71991	Leister Triac AT 230V (EU)	99
56203	Smoothing trowel	54	64310	Transport carriage for Python Classic	123	72225	Additional weight for Spider	40, 122
56204	Swiss trowel	54	65080	Cleaning pad Ø 410/20 mm brown 5 pcs.	32	72315	Heating element 1.55 kW for Triac ST	99
56205	Adhesive trowel	54	65218	Monodisc grinding machine Samba 1.700 W / 115V (UK)	27	72462	Dust ring with extraction device	28
56255	Automatic welding machine Weldmaster 230 V	96	65398	Safety Poly knee protectors	114	72661	Design Cutter WO 330	88
56259	Automatic welding machine Weldmaster 115 V (UK)	96	65431	CCM Set ECO	71	72663	Design Cutter WO 630	88
56260	Automatic welding machine Weldmaster 115 V (US)	96	65480	Stirring station, 75 l, complete	53	72752	Spare blade for WO 330	88
56303	Diamond segment SS 60	41	65481	75 l stirring station base frame	53	72776	Spare blade for WO 630	88
56306	Diamond segment SC 20	41	65491	75 l stirring station mounting	53	72916	Pre-separator 30 l	45
56308	Diamond segment SC 40	41	65492	75 l stirring station stirrer	53	72983	Grinding disc ES grit 20, black, Ø 125 mm	37, 38
56309	Diamond segment SC 60	41	65493	75 l stirring station mixing bucket	53	72984	Grinding disc BT grit 20, gold, Ø 125 mm	37, 38
56357	Grooving and welding set 230 V (EU)	97	65494	75 l stirring station hose holder	53	73102	Hose 1,2 m	47
56363	Monodisc grinding machine Jive 2,200 W / 230 rpm (EU)	29	65495	Adhesive interchangeable spatula, 28 cm with handle	56	73385	Hose kit for dust ring	28
56364	Monodisc grinding machine Samba 1,700 W / 230V (EU)	27	65496	Replacement smoothing compound rake	56	73389	Blade holder for wood flooring stripper set	13
56365	Monodisc grinding machine Flamenco 2,200 W / 154 rpm (EU)	29	65497	Universal telescopic handle	56, 57, 58	73618	Brush electrodes set BE-03	66, 68
56366	Monodisc grinding machine Tango 1,000 W 230V (EU)	29, 119	65499	Adapter for spike rollers	57, 58	73619	Flat electrodes set FE-04	66, 68
56401	Pressure roller 30 kg	89	65500	Professional hand scraper WOLFF	24	73709	Duo pressure roller	90
56402	Pressure roller 50 kg	89	65501	Smoothing compound rake, 56 cm with handle	56	73710	Joint groover with guiding wheels	95
56403	Pressure roller 68 kg	89	65502	Replacement smoothing compound rake	56	73772	Impact electrode PP-05	66, 68
56404	Wheels for transportation (for Pressure roller)	89	65503	Large area rake, 60 cm with handle	56	73773	Climate sensor CS-06 with cable	66, 68
56530	Blades for Mitre-box shears, 50 pcs.	109	65504	Replacement large area rake	56	73774	Set for resistance measurement	66, 68
59831	Cleaning tank	28	65505	Replacement pins for large area rake, 1 pair	56	73775	Hose for climate sensor	66, 68
59856	Spare screw set for Mozart trimming knife	101	65656	Solid board notched trowel	60	73888	Robo-Stripper 230 V (EU)	8
59906	Sanding machine Cobra 09 230V (UK)	123	65659	Carpet cutter	103	74000	Robo-Stripper 115 V (UK)	8
			65660	Carpet awl	103	74177	Suction kit complete 230V (EU)	28
			65755	Slot hole blades (10 pcs.)	103	74215	Twin wheels	9
			65846	30 l transportation caddy including	53	74554	Carbide phials 25 pcs.	71
			65847	30 l mixing bucket	53, 55	74650	Floor grinding machine Neo 230 230 V (EU)	39
			65848	Transportation caddy base frame	53	74843	Design Collection	84
			65853	Stair tool with roller	105	74844	Tanos carrying case for Design Collection	84
			67323	Wood Beveller 230V (EU)	106	74845	Leister Triac ST 230V (EU)	99
			67983	Handle bracket	56	74847	Leister Triac Set ST 230V (EU)	99
			68388	PCD Scraper	35	74895	Floor grinding machine Neo 230 115 V (UK)	39
			68389	PCD Split	35	74949	Chamfer and mitre templates	111
			68390	BT K20	35	75006	Spare blades 450x120x1,5 mm	9
			68391	ES K20	35	75007	Spare blades 450x60x1,5 mm	9
			68392	Ninja Disc without segments	34	75010	Special blade U-shape, 450 mm top cutting edge	9
			68602	DIA cutting blade Ø 135 (standard)	43	75011	Special blade U-shape, 450 mm bottom cutting edge	9
			68679	Screed joint cutter EF 135 230 V (EU)	43	75364	PCD ULTRA	41
			68866	Ninja complete with PCD Scraper segments	34	75365	PCD ULTRA XT	41
			68867	Ninja complete with PCD Split segments	34	75366	PCD Scraper XT	41
			68868	Ninja complete with BT K20 segments	34	75382	Floor grinding machine Neo 230 115 V (US)	39
			68869	Ninja complete with ES K20 segments	34	75404	Grinding disc PCD Split, silver, Ø 125 mm	37, 38
			68952	Monodisc grinding machine Mambo Evo 115V (US)	26	75405	Grinding disc PCD Scraper, silver, Ø 125 mm	37, 38
			69864	Railcut	83	75406	Grinding disc BT grit 20, gold, Ø 180 mm	37, 38
			69877	Spare rail with connector (1.40 m)	83			

6

60078	Safety sheath, Leather, for quarter moon knife	101
60425	Steel pins 1,5x25 mm uncoated 1.000 pcs.	109
60426	Steel pins 1,5x30 mm uncoated 1.000 pcs.	109
60427	Steel pins 1,5x35 mm uncoated 1.000 pcs.	109
60505	Cork rubbing board	90
60676	Base plate for reverse cutting for Linocut	81
60736	Spare pad for Skirting board shears	109
60800	Starvac MI55 230V (EU)	44
60865	Grooving and welding set Combi 115 V (US)	97
60890	WOLFF Wallmaster	102
60944	Suction wand for STARVAC MI55	44
60947	Floor nozzle for STARVAC MI55	44
60948	PFilter bags (5 pcs.) for STARVAC MI55	44
60949	Dry vacuum cleaner filter for STARVAC MI55	44
60950	Crevice nozzle for STARVAC MI55	44
60951	Suction hose, 4 m for STARVAC MI55	44
61201	Felt coat for glide	90
61394	WOLFF Wallmaster straight edge	102
61802	Connecting adapter 70/50	48

NUMERIC INDEX

75407	Grinding disc ES grit 20, black, ø 180 mm	36, 37, 38	81629	Dustbag endless (4 x 22 m) for Vacuclean2 LP	47	84773	Pica-Dry Marker	109
75408	Grinding disc PCD Split, silver, ø 180 mm	37, 38	81706	Vacuclean 2 LP 115 V (US)	47	84774	Refill graphit 10 pcs. for Pica-Dry Marker	109
75409	Grinding disc PCD Scraper, silver, ø 180 mm	37, 38	81715	Knee protector 200 Pro	114	84775	Refill green 10 pcs. for Pica-Dry Marker	109
76769	Leister Electron ST 230V (EU)	99	81717	Extra inlays for Knee protector 200 Pro	114	84810	Brush below for suction ring for Neo 400	40
76859	Repair-grooving machine 230V (EU)	94	81718	Extra elastics for Knee protector 200 Pro	114	84888	Duro-Stripper 2.0 230V (EU)	20
76860	HM milling blade Ø 130 x 9.0 6 teeth	94	81990	Connection piece 50 mm	46, 47	84917	Water dosing device 230V (EU)	55
76970	Floor grinding machine Neo 400 230V (EU)	40	82202	Cyclone completely assembled, dirt container, hose 1,5 m	47	84918	Roll transport trolley	113
78319	Sanding machine Spider 230V (UK)	122	82215	Pre-separator antistatic –especially for wooden dust 50 l/45		84919	Wood and screed cutter PS 230 230V (EU)	23
79320	Substrate test kit	70	82333	Deflector and oscillator set 450 mm	9	84920	Tripod for Water dosing device	55
79634	Spare blade 350 x 150 x 3,0 mm	9, 11	82348	Primo-Stripper 230V (EU)	22	85000	BiTurbo-Stripper 230V (EU)	10
79635	Spare blade serrated 350 x 150 x 3,0 mm	9, 11	82349	Primo-Stripper VG	22	85141	Distance piece for wood cutting	23
79636	Special blade 350 x 120 x 3,0 mm	16, 17	82452	Vacuclean 2 HEPA (230V EU)	46	85147	HHM-blade 230 mm (Standard)	23
79637	Special blade 350/200 x 120 x 3,0 mm	16, 17	82453	Vacuclean 2 LP HEPA (230V EU)	47	85148	PCD blade 230 mm (for wood)	23
79638	Special blade 350/100 x 120 x 3,0 mm	16, 17	82643	Leister Triac Set AT 230V (EU)	99	85149	DIA blade 230 mm (for soft floors - screed)	23
79639	Special blade 350 x 120 x 3,0 mm	16, 17	82650	Brush BS 180	36	85357	Spare wheels	21
79671	Disc holder for Spider	122	82890	Phoenix 1600 Set 115V (UK)	98	85541	DIA blade 230 mm blue (for hard floors - concrete)	23
79742	Pin rake	57, 58	83113	Universal hygrometer V1-D4 Basic	65, 68	85642	Duro-Stripper 2.0 115V (UK)	20
79922	Only Cleanspace without mask	116	83115	Thermohygrometer LVT 15 IR	67, 69	85642	Duro-Stripper 2.0 115V (US)	20
79923	Half mask large	116	83124	Cleanfox 7,5 10 Ah	119	85652	Duro-Stripper 230V VG	20
79924	Half mask medium	116	83125	Cleanfox 7,5 20 Ah	119	85860	hmbox	72
79925	Half mask small	116	83145	Cleanfox Cylindrical brush medium (blue)	119	85861	hm fix glue	72
79927	Particle filter (Packaging unit = 3 pcs.)	116	83146	Cleanfox Cylindrical brush soft (grey)	119	85963	Hose set for Water dosing device	55
79928	Pre-filter (Packaging unit = 10 pcs.)	116	83147	Cleanfox Cylindrical brush hard (black)	119	86015	Dust seal ring for Spider	122
79930	Filter adaptor	116	83148	Cleanfox Tynex brush (green – for safety surfaces)	119	87313	Spare brush set for NEO 230	39
79931	Combination filter A1P3	116	83149	Suction-lips Set Para (red)	119	87831	Hole cutter - diameter 16 – 30,5 mm	86
79932	Combination filter ABE1P3	116	83150	Cleanfox Replacement battery 10 Ah	119	87877	Rapid spatula (stainless steel) 200 mm	61
			83151	Cleanfox Replacement battery 20 Ah	119	87878	Rapid spatula (stainless steel) 270 mm	61
			83152	Cleanfox Battery charger for your car	119	87879	Plasterer spatula - width 80 mm	61
			83153	Power device for Cleanfox	119	87880	Plasterer spatula - width 100 mm	61
			83178	Flat nozzle for Vacuclean2	46, 47	87881	Serrated coating spatula – width 60 mm	61
			83248	Mixing bucket 110 l	53	87882	Serrated coating spatula – width 80 mm	61
			83338	Brush set (structuring of wooden floors)	122	87884	Floor spatula 530 mm	61
			83446	Replacement brush for floor nozzle 430 mm	46, 47	87889	Height levelling spatula 280 mm	60
			83464	Spare nails round (packaging unit 32 pieces)	63	87890	Universal holder	58
			83574	Vacuclean 2 115 V (UK)	46	87895	Rubber strips – serration 0 mm (smooth)	59
			83665	Air sensor with cable CS-10	66, 68	87896	Rubber strips – serration 2 mm	59
			83702	Stabiliser wheel for Neo 230	40	87897	Rubber strips – serration 3 mm	59
			83727	Vacuclean 2 LP 115 V (UK)	47	87898	Rubber strips – serration 4 mm	59
			83734	Rubbing device	90	87899	Rubber strips – serration 5 mm	59
			83924	Mixer Power X 1000 230V (EU)	52	87901	Rubber strips – serration 8 mm	59
			83925	Dust Mask Air+ FFP2 (10 pcs.)	115	87902	Rubber strips – serration 14 mm	59
			83926	Dust Mask Air+ FFP3 (10 pcs.)	115	87903	Cross stop for roller steel ruler (T-piece)	110
			83927	Micro fan for Air+ mask	115	87904	Cambered stainless steel	110
			83929	Microfiber cloth (for microfibre brush)	119	87905	Door straight edge 600–1200 mm	111
			83933	Suction-lips for Cleanfox	119	87907	Door straight edge, stainless short 460 - 730 mm	111
			83950	Wheels with metal rims	28	87908	Spare pushbutton 600 mm	111
			84094	Ripper	54	87909	Spare pushbutton 800 mm	111
			84137	Flow-Fix-Set	55	87910	Spare pushbutton 1.000 mm	111
			84169	Mixer Power X 1600 230V (EU)	52	87911	Combined floor covering scribe and cutter	91
			84185	Spirit Level 110 cm	111	87913	Marker pins, length 45 mm	91
			84206	Pre-filter Clean Space Ex	116	87914	Joint groover J-shape	95
			84208	Protection cover Clean Space Ex	116	87915	Spare blades J-shape, 10 pcs.	95
			84209	Cleanspace EX without mask	116	87919	Multispider	87
			84239	CleanSpace Full face mask	116	87920	Multispider Base support 450 mm	87
			84246	Dust Door System	49, 115	87921	Multispider Base support 200 mm	87
			84247	Cartridge gun 400 ml	112	87922	Multispider clamping slide	87
			84428	Laser-Distance-Analyser PT 400	73	87923	Multispider Base link	87
			84546	CCM Set Alu Business Pro	71	87924	Multispider measuring arm 250 mm	87
			84569	Microfiber cloth (green – for all sensitive floors)	119	87925	Multispider measuring arm 350 mm	87
			84659	Spare blade for Skirting board punching machine	109	87926	Multispider measuring arm 550 mm	87
			84681	Filter H14 / HEPA for Vacuclean2+LP	46, 47	87927	Multispider probe pointed/pointed	87
			84759	Carrying case for EF 135	43	87930	Multispider probe round/round	87
			84761	Paint-Checker	73	87931	Multispider probe pointed outside	87

8

80040	Levelpin	63
80071	T-Rex 230V (EU)	48
80078	Phoenix 1600 230V (EU)	98
80081	Phoenix 1600 115V (UK)	98
80113	Sanding machine Spider 230V (EU)	122
80208	Soft-head hammer	112
80229	Power Cleaner 500 ml	120
80274	Locking device for torsion joint	9
80355	Heating element Phoenix 1,6 kW 230 V	98
80358	Special blade 350 x 150 x 3,0 mm serrated in set	9, 11
80359	Special blade 350 x 150 x 3,0 mm (in set)	9, 11
80385	Sanding machine Spider 230V (US)	122
80454	Nail shoes Spiky size M, for size 42 (8) and smaller	63
80455	Nail shoes Spiky size L, for size 42 (8) – 44 (10)	63
80456	Nail shoes Spiky size XL, for size 44 (10) – 48 (15)	63
80457	Spare nails Spiky (packaging unit 32 pieces)	63
80460	Cable drum 25m	117
80578	Spare blades, 6 pcs.	91, 104
80582	Handheld grinder BS 125 230V (EU)	36
80614	Phoenix 1600 Set (EU)	98
80718	Cleaning pads, diameter 406, grey	32
80753	Spare brush set	36
81148	Vacuclean 2 230V (EU)	46
81149	Vacuclean 2 LP 230V (EU)	47
81205	Blade 350x60x1,5 mm serrated edge	16, 17
81340	Screed joint cutter EF 135 115 V (UK)	43
81446	Transport carriage Cobra/Python Classic	124, 125
81613	Standard filter class M	46, 47
81615	Filter PTFE for Vacuclean2+LP	46, 47
81618	Floor nozzle 38 mm	46, 47
81620	Suction tube	46, 47
81626	Reducer	46, 47
81627	Cone nozzle for Vacuclean2	46, 47
81628	Cable clip	47

NUMERIC INDEX

87932	Multispider probe pointed inside	87
87946	OneMix stirring rod	53
87947	OneMix stirring attachments (10 pcs.)	53
87948	Roller bracket for telescopic handle	57
87949	Handle holder for rake (joint less)	57
88300	Ergo Cutter Pro	24
88320	Spike roller 50 cm / 100 mm	58
88329	Spare blades, VE 6 pcs.	91
88367	Replacement screws for Hand scraper	24
88634	Blade case for the Turbo Stripper	15
88635	Blade case for Vario Stripper	15, 19
88784	BiTurbo-Stripper 115V (UK)	10
89000	Mastergroover 18V set EU	78
89520	Spare blades 10 pcs. in dispenser	24, 108
89521	Break-off blades 18 mm 10 pcs.	108
89522	Hooked blades 0,65 mm 10 pcs.	108
89523	Half moon blades 10 pcs.	108
89524	Titanium coated hooked blades 10 pcs.	108
89527	Super hooked blades 0,65 mm 10 pcs.	108
89530	Straight blades 0,65mm 10 pcs.	108
89531	Titanium coated super hooked blades 10 pcs.	108
89532	Titanium coated straight blades 10 pcs.	108
89563	Medical knee protectors	114
89623	HM saw blade 130x20x3,5 elliptical (standard)	75, 78
89625	HM Saw blade 130x20x2,8 round	75, 78
89658	PCD saw blade 130x20x3,8 conical	75, 78
89660	Mastergroover 18V Baretool	78
89663	Mastergroover 18V set UK	78
89664	Mastergroover 18V set USA	78

ALPHABETICAL INDEX

A	
Abrasive gauze Ø 406 mm G100	30
Abrasive gauze Ø 406 mm G120	30
Abrasive gauze Ø 406 mm G150	30
Abrasive gauze Ø 406 mm G60	30
Abrasive gauze Ø 406 mm G80	30
Abrasive gauze, Ø 150 mm for oiling 10 pcs.	32
Abrasive gauze, Ø 150 mm G100	30
Abrasive gauze, Ø 150 mm G120	30
Abrasive gauze, Ø 150 mm G150	30
Abrasive gauze, Ø 150 mm G180	30
Abrasive gauze, Ø 150 mm G60	30
Abrasive gauze, Ø 150 mm G80	30
Abrasive gauze, Ø 406 mm G180	30
Abrasive gauze, Ø 410 mm for oiling 10 pcs.	32
Abrasive paper discs, double-sided, Ø 380 mm G100	30
Abrasive paper discs, double-sided, Ø 380 mm G120	30
Abrasive paper discs, double-sided, Ø 380 mm G16	30
Abrasive paper discs, double-sided, Ø 380 mm G24	30
Abrasive paper discs, double-sided, Ø 380 mm G40	30
Abrasive paper discs, double-sided, Ø 380 mm G60	30
Abrasive paper discs, double-sided, Ø 380 mm G80	30
Abrasive paper discs, double-sided, Ø 400 mm G100	30
Abrasive paper discs, double-sided, Ø 400 mm G120	30
Abrasive paper discs, double-sided, Ø 400 mm G16	30
Abrasive paper discs, double-sided, Ø 400 mm G24	30
Abrasive paper discs, double-sided, Ø 400 mm G40	30
Abrasive paper discs, double-sided, Ø 400 mm G60	30
Abrasive paper discs, double-sided, Ø 400 mm G80	30
Adapter for corner and wall radius	86
Adapter for spike rollers	57, 58
Add-on nozzle brush set	48
Add-on nozzle rubber lip	48
Additional weight for Spider	40, 122
Additional weight, 11 kg	28
Additional weight, 30 kg for Turbo-Stripper	13
Adhesive interchangeable spatula, 28 cm with handle	56
Adhesive notch, TKB R3, 56 cm 10 pcs.	58, 62
Adhesive notch, TKB A1, 21 cm 10 pcs.	62
Adhesive notch, TKB A1, 28 cm 10 pcs.	62
Adhesive notch, TKB A2, 21 cm 10 pcs.	62
Adhesive notch, TKB A2, 28 cm 10 pcs.	62
Adhesive notch, TKB A3, 21 cm 10 pcs.	62
Adhesive notch, TKB A3, 28 cm 10 pcs.	62
Adhesive notch, TKB A4, 21 cm 10 pcs.	62
Adhesive notch, TKB A4, 28 cm 10 pcs.	62
Adhesive notch, TKB A5, 21 cm 10 pcs.	62
Adhesive notch, TKB A5, 28 cm 10 pcs.	62
Adhesive notch, TKB B1, 21 cm 10 pcs.	62
Adhesive notch, TKB B1, 28 cm 10 pcs.	62
Adhesive notch, TKB B11, 21 cm 10 pcs.	62
Adhesive notch, TKB B11, 28 cm 10 pcs.	62
Adhesive notch, TKB B2, 21 cm 10 pcs.	62
Adhesive notch, TKB B2, 28 cm 10 pcs.	62
Adhesive notch, TKB B3, 21 cm 10 pcs.	62
Adhesive notch, TKB B3, 28 cm 10 pcs.	62
Adhesive notch, TKB B9, 28 cm 10 PCS.	62
Adhesive notch, TKB R1, 21 cm 10 pcs.	62
Adhesive notch, TKB R1, 28 cm 10 pcs.	62
Adhesive notch, TKB R1, 56 cm 10 pcs.	58, 62
Adhesive notch, TKB R2, 21 cm 10 pcs.	62
Adhesive notch, TKB R2, 28 cm 10 pcs.	62
Adhesive notch, TKB R2, 56 cm 10 pcs.	58, 62
Adhesive notch, TKB S2, 21 cm 10 pcs.	62
Adhesive notch, TKB S2, 28 cm 10 pcs.	62
Adhesive notch, TKB S3, 21 cm 10 pcs.	62
Adhesive notch, TKB S3, 28 cm 10 pcs.	62
Adhesive spatula A1, 25 cm	60
Adhesive spatula A2, 18 cm	60
Adhesive spatula A2, 25 cm	60
Adhesive spatula B1, 18 cm	60
Adhesive spatula B2, 18 cm	60
Adhesive spatula B2, 25 cm	60
Adhesive spatula B3, 18 cm	60
Adhesive spatula B3, 25 cm	60
Adhesive spatula, A1, 18 cm	60
Adhesive spatula, B1, 25 cm	60
Adhesive spatula, B11, 18 cm	60
Adhesive spatula, B11, 25 cm	60
Adhesive spatula, w/o profile, 25 cm	60
Adhesive spatula, w/o profile 18 cm	60
Adhesive trowel	54
Adjustable knee kicker	103
Air cleaner LR 690 230V (EU)	49, 115
Air hose connection adapter 205 mm diameter	49
Air sensor with cable CS-10	66, 68
Allen key SW 8 for Disc holder	30
Aluminium floor nozzle, 370 mm for STARVAC MI55	44
Automatic welding machine Weldmaster 115 V (UK)	96
Automatic welding machine Weldmaster 115 V (US)	96
Automatic welding machine Weldmaster 230 V	96
B	
Ball set, 4 pcs.	71
Base for chamfering the floor backing	91
Base plate for removing factory-cut edges	81
Base plate for reverse cutting for Linocut	81
Basic grinding disc for diamond segments	33
Bevelling disc for profile bevels	106
BiTurbo-Stripper 115V (UK)	10
BiTurbo-Stripper 230V (EU)	10
Blade 350x60x1,5 mm serrated edge	16, 17
Blade case for the Turbo Stripper	15
Blade case for Vario Stripper	15, 19
Blade holder for Mitre-box shears for design floors	109
Blade holder for parquet deflector for Turbo2	13
Blade holder for wood flooring stripper set	13
Blade no. 22, 10 pcs.	108
Blades for Mitre-box shears, 50 pcs.	109
Bolt with left-handed thread	30
Bolt with nut and sleeve (Set)	109
Break-off blade 18 mm, 100 pcs.	108
Break-off blades 18 mm 10 pcs.	108
Break-off knife	108
Broad nozzle 20 mm	100
Broad nozzle 20 mm, angled	100
Broad nozzle 40 mm	100
Brooms, horsehair blend, 50 cm	113
Brooms, horsehair blend, 60 cm	113
Brush below for suction ring for Neo 400	40
Brush BS 180	36
Brush cup plate	31
Brush cup set, 6 pcs.	31
Brush electrodes set BE-03	66, 68
Brush ring	28
Brush ring, high	31
Brush set (structuring of wooden floors)	122
Brush set roller nozzle for T-Rex	48
BT K20	35
C	
Cable clip	47
Cable drum 25m	117
Carbide phials 100 pcs.	71
Carbide phials 25 pcs.	71
Cambered stainless steel	110
Carpet awl	103
Carpet base 8 mm guide	81
Carpet clamp	24
Carpet clamp with wooden handle	24
Carpet cutter	103
Carpet cutter, green	104
Carpet cutter, red	104
Carpet shears for right-handed users, 25 cm	105
Carpet shears, serrated blade, 22 cm	105
Carpet strip cutter	104
Carpet strip cutter C-cut	104
Carrying case for EF 135	43
Carrying case for Gecko Flex	126
Cartridge gun 400 ml	112
CCM device classic	71
CCM Set Alu Business Pro	71
CCM Set ECO	71
Chamfer and mitre templates	111
Charger 115V USA	75, 76, 77, 78, 79
Charger 230V EU	75, 76, 77, 78, 79
Charger 230V UK	75, 76, 77, 78, 79
Chassis for BiTurbo, Turbo and Extro Strippers	11, 13, 14
Circular cutter	86
Circular cutter, 4 - 21 cm	104
Claw tool	105
Cleanfox 7,5 10 Ah	119
Cleanfox 7,5 20 Ah	119
Cleanfox Battery charger for your car	119
Cleanfox Cylindrical brush hard (black)	119
Cleanfox Cylindrical brush medium (blue)	119
Cleanfox Cylindrical brush soft (grey)	119
Cleanfox Replacement battery 10 Ah	119
Cleanfox Replacement battery 20 Ah	119

ALPHABETICAL INDEX

Cleanfox Tynex brush (green – for safety surfaces)	119	Corundum abrasive belts 200 x 550 mm G80 10 PCS.	127	Disc holder with sponge padding, Ø 400 mm	30
Cleaning pad Ø 150 mm beige 10 pcs.	32	Corundum abrasive belts 200 x 750 mm G100 10 PCS.	127	Disposable inlays, Cobra 09 , 10 pcs.	123, 124
Cleaning pad Ø 150 mm black 10 pcs.	32	Corundum abrasive belts 200 x 750 mm G12 10pcs.	127	Distance piece for wood cutting	23
Cleaning pad Ø 150 mm green 10 pcs.	32	Corundum abrasive belts 200 x 750 mm G120 10 PCS.	127	Door case saw Piranha 230V (EU)	106
Cleaning pad Ø 150 mm red 10 pcs.	32	Corundum abrasive belts 200 x 750 mm G16 10 PCS.	127	Door case saw Piranha 115V (UK)	106
Cleaning pad Ø 150 mm white 10 pcs.	32	Corundum abrasive belts 200 x 750 mm G24 10 PCS.	127	Door case saw Piranha 115V (US)	106
Cleaning pad Ø 410/20 mm brown 5 pcs.	32	Corundum abrasive belts 200 x 750 mm G30 10 PCS.	127	Door straight edge 600–1200 mm	111
Cleaning pad Ø 410/20 mm red 5 pcs.	32	Corundum abrasive belts 200 x 750 mm G36 10 PCS.	127	Door straight edge, stainless short 460 - 730 mm	111
Cleaning pad Ø410/10 mm red 10 pcs.	32	Corundum abrasive belts 200 x 750 mm G40 10 PCS.	127	Double head stretcher	103
Cleaning pads Ø 410/10 mm beige 10 PCS.	32	Corundum abrasive belts 200 x 750 mm G50 10 PCS.	127	Double knife sheath	108
Cleaning pads Ø 410/10 mm black 10 PCS.	32	Corundum abrasive belts 200 x 750 mm G60 10 PCS.	127	Double knife sheath	108
Cleaning pads Ø 410/10 mm green 10 PCS.	32	Corundum abrasive belts 200 x 750 mm G80 10 PCS.	127	Drive belt Turbo	13
Cleaning pads Ø 410/10 mm white 10 PCS.	32	Corundum abrasive belts 250 x 750 mm G100 10 pcs.	127	Dry vacuum cleaner filter for STARVAC MI55	44
Cleaning pads Ø 410/20 mm beige 5 PCS.	32	Corundum abrasive belts 250 x 750 mm G120 10 pcs.	127	Duo pressure roller	90
Cleaning pads Ø 410/20 mm black 5 PCS.	32	Corundum abrasive belts 250 x 750 mm G24 10 pcs.	127	Duro-Stripper 2.0 115V (UK)	20
Cleaning pads Ø 410/20 mm green 5 PCS.	32	Corundum abrasive belts 250 x 750 mm G36 10 pcs.	127	Duro-Stripper 2.0 115V (US)	20
Cleaning pads Ø 410/20 mm white 5 PCS.	32	Corundum abrasive belts 250 x 750 mm G40 10 pcs.	127	Duro-Stripper 2.0 230V (EU)	20
Cleaning pads, diameter 406, grey	32	Corundum abrasive belts 250 x 750 mm G60 10 pcs.	127	Duro-Stripper 230V VG	20
Cleaning tank	28	Corundum abrasive belts 250 x 750 mm G80 10 pcs.	127	Dust absorbing pad 410 mm	31
Cleaning tank for Mambo Evo	26	Cover plate for dust formation during mixing	49	Dust bag Cobra 09/Classic/Python Cl	123, 124, 125
Cleanspace EX without mask	116	Crevice nozzle for STARVAC MI55	44	Dust Door System	49, 115
CleanSpace Full face mask	116	Cross stop for roller steel ruler (T-piece)	110	Dust mask	115
Climate sensor CS-06 with cable	66, 68	Cyclone completely assembled, dirt container, hose 1,5 m	47	Dust Mask Air+ FFP2 (10 pcs.)	115
CM pressure gauge	71			Dust Mask Air+ FFP3 (10 pcs.)	115
Coarse filter G4, 1100 m ³ < 45 Pa	49			Dust ring	28
Coir broom, 60 cm	113			Dust ring with extraction device	28
Combi grooving disc, 5 mm	92, 93	D		Dust seal ring for Spider	122
Combi scriber	91	Deflector and oscillator set 450 mm	9	Dustbag endless (4 x 22 m) for Vacuclean2 LP	47
Combination filter A1P3	116	Deflector for new Turbo version 2	13		
Combination filter ABE1P3	116	Design Collection	84	E	
Combined floor covering scriber and cutter	91	Design Cutter WO 330	88	Easycut	104
Combined hooked/straight blade 100 pcs.	108	Design Cutter WO 630	88	Edge sanding machine Gecko Flex 230V (EU)	126
Compact air hose, 125 mm Ø / 6 m length, black	49	Designer cutting knife	108	Electric strip cutter LS35 230V (EU)	85
Compact air hose, 205 mm Ø / 7,5 m length, black	49	DIA blade 230 mm (for soft floors - screed)	23	Electric strip cutter LS65 230V (EU)	85
Cone nozzle for Vacuclean2	46, 47	DIA blade 230 mm blue (for hard floors - concrete)	23	End fitting 70 mm	48
Connecting adapter 70/50	48	DIA cutting blade Ø 135 (standard)	43	Ergo Cutter Pro	24
Connecting kit, 50 mm for T-Rex	48	Diamond grinding disc Raptor	38	Ergostar spatula 21 cm	60
Connecting piece (T40 & T-Rex) 70 mm diameter	48	Diamond grinding disc, double row	38	Ergostar spatula 28 cm	60
Connection piece 50 mm	46, 47	Diamond grinding disc, single row	38	ES K20 35	
Conversion kit for diamond grinding disc	41	Diamond grinding head, fan-type helical design	33	Exhaust air hose transparent 125 mm Ø x 0,15 mm, 88 meters	49
Conversion kit, to use hooked blade	85	Diamond grindstone	101	Extension cable	40, 117
Copper band, Roll 2 x 25 m, Self-adhesive roll (10 mm)	63	Diamond grindstone	101	Extension cable black 1.5 ²	117
Copper band, Roll 200 m (width: 10 mm)	63	Diamond milling blade elliptical 130 x 3.8, Z4	92, 93	Extension cable, 25,0 m, 2,5 ²	26, 28, 42, 117
Copper band, Roll 50 m (width: 10 mm)	63	Diamond segment SC 20	41	Extension cable, l 12,5 m, 2,5 ²	117
Cordless Mixer Power X 18V only	76	Diamond segment SC 40	41	Extension rails up to 4.86 m radius	86
Cordless Mixer Power X 18V set EU	76	Diamond segment SC 60	41	External starting current limiter (with Swiss plug)	117
Cordless Mixer Power X 18V set UK	76	Diamond segment SS 20	41	Extra elastics for Knee protector 200 Pro	114
Cordless Mixer Power X 18V set USA	76	Diamond segment SS 40	41	Extra inlays for Knee protector 200 Pro	114
Cork rubbing board	90	Diamond segment SS 60	41	Extro-Stripper 115V (UK)	14
Correction nozzle, 4 mm	100	Digital CM pressure gauge	71	Extro-Stripper 115V (US)	14
Corrugated link, 1,000 pcs.	43, 63	Digital scale	71	Extro-Stripper 230V (EU)	14
Corrugated link, 1,000 pcs.	43, 63	Disc holder for pads	119		
Corrugated wire brush	32, 120	Disc holder for pads Ø 400 mm	32	F	
Corundum abrasive belts 200 x 550 mm G16 10 PCS	127	Disc holder for Spider	122	FasTrimmer	91
Corundum abrasive belts 200 x 550 mm G24 10 PCS.	127	Disc holder with felt Ø 375 mm	30	FasTrimmer for chamfering floor backings	91
Corundum abrasive belts 200 x 550 mm G36 10 PCS.	127	Disc holder with felt, Ø 375 mm	30		
Corundum abrasive belts 200 x 550 mm G40 10 PCS.	127	Disc holder with Spare sponge padding, Ø 375 mm	30		
Corundum abrasive belts 200 x 550 mm G60 10 PCS.	127	Disc holder with spare sponge padding, Ø 400 mm	30		
		Disc holder with sponge padding, Ø 375 mm	30		

ALPHABETICAL INDEX

K

Knee pads	114
Knee protector 200 Pro	114
Knee protectors with velcro fastener	114

L

Large area rake, 60 cm with handle	56
Large dust ring for Mambo Evo	26
Large spare brush for Mambo Evo	26
Laser-Distance-Analyser PT 400	73
Leather knee protectors	114
Leister Electron ST 230V (EU)	99
Leister Triac AT 230V (EU)	99
Leister Triac Set AT 230V (EU)	99
Leister Triac Set ST 230V (EU)	99
Leister Triac ST 230V (EU)	99
Levelpin	63
Linocut seam cutter	81
Linoleum edge cutter	86
Locking device for torsion joint	9

M

Marker pins, length 45 mm	91
Mastergroover 18V only	78
Mastergroover 18V set EU	78
Mastergroover 18V set UK	78
Mastergroover 18V set USA	78
Measuring wedge	70
Medical knee protectors	114
Membrane filter for STARVAC MI55	44
Metal carrying case	21
Metal handle	113
Micro fan for Air+ mask	115
Microfiber cloth (for microfibre brush)	119
Microfiber cloth (green – for all sensitive floors)	119
Milling blade set for CT 200, 76 pcs.	42
Milling disc with rotation principle	33
Milling drum CT 200 (not shown) without blades	42
Milling drum CT 200 complete with peeling blades	42
Milling drum CT 200 complete with star-shaped blades	42
Milling drum CT 200 with milling blades	42
Milling module with HM plate	33
Mipolam nozzle	100
Mitre-box shears	109
Mitre-box shears for design floors	109
Mitre-box stop 90 degrees for Skirting board shears	109
Mittag cutter	103
Mixed adhesive for PressoMess	71
Mixer Power X 1000 230V (EU)	52
Mixer Power X 1600 230V (EU)	52
Mixing bucket 110 l	53
Mixing bucket 30 l	53, 55
Moisture meter GM-200	67
Monodisc grinding machine Samba 1,700 W / 115V (UK)	27
Monodisc grinding machine Samba 1,700 W / 115V (US)	27

Monodisc grinding machine Samba 1,700 W / 230V (EU)	27
Monodisc grinding machine Flamenco 2,200 W / 154 rpm (EU)	29
Monodisc grinding machine Jive 2,200 W / 230 rpm (EU)	29
Monodisc grinding machine Mambo Evo 115V (UK)	26
Monodisc grinding machine Mambo Evo 115V (US)	26
Monodisc grinding machine Mambo Evo 230V (EU)	26
Monodisc grinding machine Tango 1,000 W 230V (EU)	29, 119
Mounting kit for brush cup set	31
Mozart Speed Trimmer	101
Mozart trimming knife	101
Multi grinding plate	31
Multispider	87
Multispider Base link	87
Multispider Base support 200 mm	87
Multispider Base support 450 mm	87
Multispider clamping slide	87
Multispider measuring arm 250 mm	87
Multispider measuring arm 350 mm	87
Multispider measuring arm 550 mm	87
Multispider probe pointed inside	87
Multispider probe pointed outside	87
Multispider probe pointed/pointed	87
Multispider probe round/round	87

N

Nail shoes	63
Nail shoes Spiky size L, for size 42 (8) – 44 (10)	63
Nail shoes Spiky size M, for size 42 (8) and smaller	63
Nail shoes Spiky size XL, for size 44 (10) – 48 (15)	63
Napping shears, 14 cm	105
Napping shears, 18 cm	105
Needle punch base 4 mm guide	81
Ninja complete with BT K20 segments	34
Ninja complete with ES K20 segments	34
Ninja complete with PCD Scraper segments	34
Ninja complete with PCD Split segments	34
Ninja Disc without segments	34
Nylon roller	59

O

OneMix stirring attachments (10 pcs.)	53
OneMix stirring rod	53
Only Cleanspace without mask	116

P

Paint-Checker	73
Paper filter bags 40 cm	28
Paper filter bags 80 cm	28
Particle filter (Packaging unit = 3 pcs.)	116
PCD blade 230 mm (for wood)	23
PCD saw blade 130x20x3,8 conical	75, 78
PCD Scraper	35
PCD Scraper XT	41
PCD splinter segment	41

PCD Split	35
PCD ULTRA	41
PCD ULTRA XT	41
PCD Viper	41
PCD Viper XT	41
Peeling blade set for CT 200, 40 pcs., 10 mm	42
Perforated pad, G100 Ø 410 mm	32
Perforated pad, G120 Ø 410 mm	32
Perforated pad, G150 Ø 410 mm	32
Perforated pad, G220 Ø 410 mm	32
Perforated pad, G320 Ø 150 mm	32
Perforated pad, G320 Ø 410 mm	32
Perforated pad, G36 Ø 410 mm	32
Perforated pad, G40 Ø 150 mm	32
Perforated pad, G40 Ø 410 mm	32
Perforated pad, G400 Ø 410 mm	32
Perforated pad, G60 Ø 150 mm	32
Perforated pad, G60 Ø 410 mm	32
Perforated pad, G80 Ø 150 mm	32
Perforated pad, G80 Ø 410 mm	32
Perforated pads, G100 Ø 150 mm	32
Perlon brush, hard	32, 120
PFilter bags (5 pcs.) for STARVAC MI55	44
Phoenix 1600 115V (UK)	98
Phoenix 1600 230V (EU)	98
Phoenix 1600 Set 115V (UK)	98
Phoenix 1600 Set 230V (EU)	98
Pica-Dry Marker	109
Pin leveller	57, 58
Pin rake	57, 58
Piranha 18V only	79
Piranha 18V set EU	79
Piranha 18V set UK	79
Piranha 18V set USA	79
PKD-segment	41
Plasterer spatula - width 100 mm	61
Plasterer spatula - width 80 mm	61
Polishing brush, coir	32, 120
Polishing brush, hard	119
Polishing brush, soft	119
Polishing machine Rumba 0.5 kW 230V (EU)	119
Polishing pad, Ø 325 mm	119
Pouring spouts (10 St.)	53
Power Cleaner 500 ml	120
Power device for Cleanfox	119
Pre-filter (Packaging unit = 10 pcs.)	116
Pre-filter Clean Space Ex	116
Pre-filter mats G3, 340 x 405 mm (10 pcs.)	49
Pre-separator 30 l	45
Pre-separator antistatic –especially for wooden dust 50 l	45
PressoMess shear strength measuring instrument	71
Pressure roller 30 kg	89
Pressure roller 50 kg	89
Pressure roller 68 kg	89
Pressure roller for floor coverings	90
Primo-Stripper 230V (EU)	22
Primo-Stripper VG	22
Professional hand scraper WOLFF	24
Protection cover Clean Space Ex	116

ALPHABETICAL INDEX

Protective goggles	115	Safety sheath, Leather, for quarter moon knife	101	Spare blade for WO 630	88
PUR welding nozzle	100	Sample collection	60	Spare blade serrated 350 x 150 x 3,0 mm	9, 11
Q					
Quarter moon knife	101	Sanding disc with 6 stones grit 20	33	Spare Blades Turbo 150x60x1,5 mm 10 pcs.	16
Quarter moon knife, angled	101	Sanding machine Cobra 09 230V (EU)	123	Spare Blades Turbo 200x60x1,5 mm 10 pcs.	16
Quarter moon knife, bent	101	Sanding machine Cobra 09 230V (UK)	123	Spare Blades Turbo 350x60x1,5 mm 10 pcs.	16, 17
R					
Radiator nozzle	100	Sanding machine Cobra 09 230V (US)	123	Spare blades (hook-break-off blades) PU 10 pcs.	104
Railcut	83	Sanding machine Cobra Classic 230V (EU)	124	Spare blades 10 pcs. in dispenser	24, 108
Rake to apply smoothing compounds	57, 58	Sanding machine Python Classic	125	Spare blades 450x120x1,5 mm	9
Rapid spatula (stainless steel) 200 mm	61	Sanding machine Spider 230V (EU)	122	Spare blades 450x60x1,5 mm	9
Rapid spatula (stainless steel) 270 mm	61	Sanding machine Spider 230V (UK)	122	Spare blades for Carpet cutter, green, 10 pcs.	104
Reducer	46, 47	Sanding machine Spider 230V (US)	122	Spare blades for Circular cutter, 6 pcs.	86
Refill graphit 10 pcs. for Pica-Dry Marker	109	Sanding roller Cobra 09/Cobra Classic	123, 124	Spare blades for Hand scraper, 100 pcs. in box	24, 108
Refill green 10 pcs. for Pica-Dry Marker	109	Sanding roller for Python Classic 230V (EU)	125	Spare blades for Linocut, 10 pcs.	81
Reinigungstank	119	Screed joint cutter EF 135 115 V (UK)	43	Spare blades for Mittag cutter (10 pcs.)	103, 104
Repair-grooving machine 230V (EU)	94	Screed joint cutter EF 135 230 V (EU)	43	Spare blades for Mozart trimming knife, 5 pcs.	101
Replacement battery 18V 5Ah (1 piece)	75, 76, 77, 78, 79	Scriber needles, 20 pcs.	91	Spare blades for Strip cutter, 5 pairs	85
Replacement brush for floor nozzle 430 mm	46, 47	Scrub brush	32, 120	Spare blades J-shape, 10 pcs.	95
Replacement large area rake	56	Seal rings (3 small + 3 large rings)	71	Spare Blades Turbo 350x120x1,5 mm	13, 16, 17
Replacement pins for large area rake, 1 pair	56	Seam clamp 5 pcs.	105	Spare Blades Turbo 350x60x1,0 mm 10 pcs.	16, 17
Replacement screws for Hand scraper	24	Seam roller, 13 cm wide	105	Spare blades U-shape, 10 pcs.	95
Replacement smoothing compound rake	56	Seam scriber	91	Spare blades, 5 pcs.	86, 91
Replacement smoothing compound rake	56	Seam trimmer	95	Spare blades, 6 pcs.	91, 104
Ripper	54	Semicircular HM grooving disc, 3.3 mm	92, 93	Spare blades, VE 6 pcs.	91
Robo-Stripper 115 V (UK)	8	Serrated blades 210 x 60 x 1,0 mm	21, 22	Spare brush set	36
Robo-Stripper 230 V (EU)	8	Serrated blades 250 x 60 x 1,0 mm	19	Spare brush set for NEO 230	39
Roll transport trolley	113	Serrated coating spatula – width 60 mm	61	Spare nails round (packaging unit 32 pieces)	63
Roller bracket for telescopic handle	57	Serrated coating spatula – width 80 mm	61	Spare nails Spiky (packaging unit 32 pieces)	63
Roller container	59	Set for resistance measurement	66, 68	Spare pad for Disc holder Ø 400 mm	32
Roller handle	59	Shafts for milling drum CT 200, set of 4 pcs.	42	Spare pad for Mitre-box shears	109
Roller nozzle T-Rex	48	Shampooing brush	32, 120	Spare pad for Skirting board shears	109
Rough base plate for adjustable knee kicker	103	Sheath for Break-off knife	108	Spare pins, 2 pcs.	58
Round blade for Seam trimmer, 12 mm	95	Single milling module for Milling disc with rotation principle	33	Spare pushbutton 1.000 mm	111
Round blade for Seam trimmer, 6 mm	95	Single nozzle, 5mm	100	Spare pushbutton 600 mm	111
Round nozzle for Leister Electron ST	99	Skirting board punching machine	109	Spare pushbutton 800 mm	111
Rubber knee protectors	114	Skirting board shears with stop	109	Spare rail with connector (1.40 m)	83
Rubber mallet, 335 g, 40 mm	112	Slide hammer tool, 41 cm	113	Spare screw set for Mozart trimming knife	101
Rubber mallet, 600 gr, 50 mm	112	Slide hammer tool, adjustable, 41/64 cm	113	Spare spring for Skirting board punching machine	109
Rubber strips – serration 0 mm (smooth)	59	Slider for Mozart trimming knife, 0.70 mm	101	Special 350 mm U-shape blade, Angled	16
Rubber strips – serration 14 mm	59	Slider, 0.50 mm for Mozart trimming knife	101	Special 350 mm U-shape blade, Top cutting edge	16
Rubber strips – serration 2 mm	59	Slot hole blades (10 pcs.)	103	Special blade 350 x 120 x 3,0 mm	16, 17
Rubber strips – serration 3 mm	59	Smashing bowl for CCM-instruments	71	Special blade 350 x 120 x 3,0 mm	16, 17
Rubber strips – serration 4 mm	59	Smoothing compound rake, 56 cm with handle	56	Special blade 350 x 150 x 3,0 mm (in set)	9, 11
Rubber strips – serration 5 mm	59	Smoothing trowel	54	Special blade 350 x 150 x 3,0 mm serrated in set	9, 11
Rubber strips – serration 8 mm	59	Soft-head hammer	112	Special blade 350/100 x 120 x 3,0 mm	16, 17
Rubbing device	90	Solid board notched trowel	60	Special blade 350/200 x 120 x 3,0 mm	16, 17
Rubbing hammer	90	Spare blade 210x60x0,7mm 10 PCS.	21, 22	Special blade for stripper versions 2	13
S					
Safety gloves	115	Spare blade 210x60x1,0mm 10 PCS.	21, 22	Special blade U-shape, 450 mm bottom cutting edge	9
Safety Poly knee protectors	114	Spare blade 210x60x1,5mm 10 PCS.	21, 22	Special blade U-shape, 450 mm top cutting edge	9
		Spare blade 250x60x0,7 mm Vario 10 pcs.	19	Special blade, Heavy duty, angled, 350 mm	13
		Spare blade 250x60x1,0 mm Vario 10 pcs.	19	Special U-shape blade, 250 mm, Bottom cutting edge	19
		Spare blade 250x60x1,5 mm Vario 10 pcs.	19	Special U-shape blade, 250 mm, Top cutting edge	19
		Spare blade 350 x 150 x 3,0 mm	9, 11	Speed welding nozzle	99, 100
		Spare blade for Floor scraper	24	Speed welding nozzle	100
		Spare blade for Groover	86, 95	Speed welding nozzle for polyolefin Ø 4 mm	100
		Spare blade for Mitre-box shears	109	Speed welding nozzle for polyolefin, Ø 5mm	98, 100
		Spare blade for Skirting board punching machine	109	Spare wheels	21
		Spare blade for Skirting board shears	109	Spike roller 25 cm / 11 mm	58
		Spare blade for WO 330	88	Spike roller 25 cm / 21 mm	58

ALPHABETICAL INDEX

Spike roller 50 cm / 100 mm	58	Strip cutter, 6 - 30 cm	85	Universal floor laying knife	108
Spike roller 50 cm / 11 mm	58	Subfloor strength tester	70	Universal holder	58
Spike roller 50 cm / 21 mm	58	Submersible probe TF-01	67, 69	Universal hygrometer V1-D4 Professional	65, 68
Spike roller 50 cm / 31 mm	58	Substrate test kit	70	Universal hygrometer V1-D4 Professional	65, 68
Spike roller 75 cm / 11 mm	58	Suction hose, 4 m for STARVAC MI55	44	Universal shears, 25 cm	105
Spike roller 75 cm / 21 mm	58	Suction hose, 50 mm, length 5 m	46, 47, 48	Universal telescopic handle	56, 57, 58
Spike rollers 25 cm / 31 mm	58	Suction hose, 70 mm diameter, (15 m)	48		
Spike rollers 75 cm / 31 mm	58	Suction kit complete 230V (EU)	28		
Spirit Level 110 cm	111	Suction kit complete 230V (EU)	28		
Spring scale CCM-instruments	71	Suction tube	46, 47		
Spring washer	30	Suction wand 50 mm T-Rex	48	V	
Stabiliser wheel for Neo 230	40	Suction wand for STARVAC MI55	44	Vacuclean 2 230 V	46
Stair bevel	111	Suction-wips for Cleanfox	119	Vacuclean 2 HEPA	46
Stair scribe	91	Suction-wips Set Para (red)	119	Vacuclean 2 LP 115 V (UK)	47
Stair tool with roller	105	Super fine foam roller	59	Vacuclean 2 LP 115 V (US)	47
Stair tool, 7 cm	105	Super hooked blade with titanium coating, 100 pcs.	108	Vacuclean 2 LP 230 V (EU)	47
Stair tool, 9 cm	105	Super hooked blade, 0.65 mm, 100 pcs.	82, 108	Vacuclean 2 LP HEPA (EU)	47
Standard base 2 mm guide	81	Super hooked blades 0,65 mm 10 pcs.	108	Vacuum with holding basket	28
Standard filter class M	46, 47	Supporting blocks for PressoMess, 100 pcs.	71	Vario-Stripper Silent 115V (UK)	18
Star-shaped blade set for CT 200, 356 pcs.	42	Surface probe OF-02	67, 69	Vario-Stripper Silent 115V (US)	18
Starter Set for T-Rex	48	Swiss trowel	54	Vario-Stripper Silent 230V (EU)	18
Starting current limiter	42, 117			Velcro fastener for Medical knee protectors	114
Starvac disposal bags (10 pcs.) for STARVAC MI55	44				
Starvac MI55 230V (EU)	44	T			
Steel blade for Pin leveller	58	T-Rex 230V (EU)	48		
Steel pins 1,5x25 mm uncoated 1.000 pcs.	109	T-Rex 115V (UK)	48	W	
Steel pins 1,5x30 mm uncoated 1.000 pcs.	109	T-Rex 50 mm connecting piece	48	Water dosing device 230V (EU)	55
Steel pins 1,5x35 mm uncoated 1.000 pcs.	109	T-Rex 70 mm add-on nozzle	48	Web for Strip cutter, 5 pcs.	85
Stirrer Typ MK 120 mm	52	T-Rex absolute filter (HEPA)	48	Weld seam slide	101
Stirrer Typ MK 160 mm	52, 53	T-Rex suction nozzle, round	48	Welding rod roller 15 mm	95, 100
Stirrer, type KE 120S	52	Tanos carrying case for Design Collection	84	Welding rod roller 25 mm	95, 100
Stirrer, type KE 120S (M14 thread)	52	Tapping block	112	Wet and dry vacuum cleaner filter for Starvac MI55	44
Stirrer, type KE 90S	52	Teller z. Reinigen von Naturstein	32, 120	Wheel set per module, 12 pcs.	33
Stirrer, type KR - 140	52	Test blocks for PressoMess, 100 pcs.	71	Wheels for transportation (for Pressure roller)	89
Stirring station base frame 75 I	53	Test phials, 10 pcs.	71	Wheels with metal rims	28
Stirring station hose holder 75 I	53	Thermohygrometer LVT 15 IR	67, 69	WOLFF Wallmaster	102
Stirring station mixing bucket 75 I	53	Thermohygrometer LVT 15 Professional	67, 69	WOLFF Wallmaster straight edge	102
Stirring station mounting 75 I	53	Three-star grip screw M 10 x 80	12	Wood and screed cutter PS 230 230V (EU)	23
Stirring station stirrer 75 I	53	Three-star nut D 80 x M 10	12, 14	Wood Beveller 230V (EU)	106
Stirring station, 75 I, complete	53	Titanium coated hooked blades 10 pcs.	108	Wood flooring stripper set Turbo2	13
Stone, grit 20	33	Titanium coated straight blades 10 pcs.	108		
Straight blade with titanium coating, 100 pcs.	108	Titanium coated super hooked blades 10 pcs.	108		
Straight blades (100 pcs.)	24, 82, 83, 108	Transport carriage Cobra/Python Classic	124, 125	Z	
Straight blades 0,65mm 10 pcs.	108	Transport carriage for Python Classic	123	Zirconia abrasive belts 200 x 750 mm G100 10 PCS.	127
Strip Cutter LS35 18V only	77	Transportation caddy base frame	53	Zirconia abrasive belts 200 x 750 mm G120 10 PCS.	127
Strip Cutter LS35 18V set EU	77	Transportation caddy including 30 I	53	Zirconia abrasive belts 200 x 750 mm G24 10 PCS.	127
Strip Cutter LS35 18V set UK	77	Tripod for Water dosing device	55	Zirconia abrasive belts 200 x 750 mm G36 10 PCS.	127
Strip Cutter LS35 18V set USA	77	TS 40/T-Rex 50 mm end fitting	48	Zirconia abrasive belts 200 x 750 mm G40 10 PCS.	127
Strip Cutter LS65 18V only	77	Turbo-Stripper 230V (EU)	12	Zirconia abrasive belts 200 x 750 mm G60 10 PCS.	127
Strip Cutter LS65 18V set EU	77	Twin wheels	9	Zirconia abrasive belts 200 x 750 mm G80 10 PCS.	127
Strip Cutter LS65 18V set UK	77				
Strip Cutter LS65 18V set USA	77				
Strip cutter, 0 - 8 cm	85	U			
Strip cutter, 3 - 20 cm	85	Undercarriage protection for Turbo-Stripper	13		





Your Floor. Our Passion.

The Uzin Utz Group represents the complete range of flooring competence.

For all questions concerning flooring we are a competent and reliable partner.



UZIN. THE FLOOR BELONGS TO YOU.

Installation systems for screeds, flooring and wood flooring.



WOLFF going beyond your limits

Machinery and special tools for subfloor preparation and installation of floor coverings.



PALLMANN My wood floor. My life.

Complete product range for the installation, renovation and maintenance of wood flooring.



Arturo what a floor can do.

Functional floor coatings with manifold design options.



codex exclusive to real tilers.

Installation systems for tiles and natural stone.



Pajarito Made by professionals for professionals.

Tools for floor, wall and ceiling.



WOLFF | A COMPANY OF UZIN UTZ AG

Wolff GmbH & Co. KG
Ungerhalde 1 | 74360 Ilsfeld
Phone +49 7062 91556-0 | Fax +49 7062 91556-10
Email info@wolff-tools.com | Internet www.wolff-tools.de

Your Contacts at WOLFF:

WOLFF GmbH & Co. KG
Ungerhalde 1 | 74360 Ilsfeld
Phone +49 7062 91 55 6 - 0
Fax +49 7062 91 55 6 - 44
Email info@wolff-tools.com

Customer service | orders:

Phone +49 731 40 97-301
Fax +49 731 40 97-230
Email bestellung@wolff-tools.com

Technical customer service:

Phone +49 7062 91 55 6 -28
Fax +49 7062 91 55 6 - 55
Email info@wolff-tools.com



Approved by
OFFSET COMPANY
2022-12

FLEX SCANDINAVIA AB – SVENSK ÅTERFÖRSÄLJARE FÖR WOLFF GMBH & CO

Box 5040, 650 05 KARLSTAD. www.flexscandinavia.se

För order, frågor och mera information om Wolff produkterna kontakta Flex Service Center (FSC)
Mathias Nyman 054-52 20 08, service@flexscandinavia.se eller din lokala säljare.

